

CATALOG

# InLine II

## ZLBM/ZHBM/BZL/BZH

### Fuse switch disconnectors



- High performance
- Safety and protection
- Convenience and ease
- Continuous operation







---

# Table of contents

<b>01. Introduction</b>	04
<b>02. Ordering Information</b>	24
<b>03. Dimensional drawings</b>	59



—  
**01**

# **Introduction**



# Introduction

<b>InLine II</b>	
Safety and protection	10
Convenience and ease	12
Continuous operation	14
Electronic Fuse Monitoring (EFM)	15
ITS2 monitoring unit	16
Type codes and product configuration	18
<b>Technical data</b>	
ZLBM, ZHBM, BZL, BZH	19
Derating tables	23



---

# InLine II

## Applications

InLine II covers a wide range of distribution applications from single panels to industrial, residential, and commercial buildings.



- Office buildings
- Shopping malls
- Warehouses



- Water treatment plants
- Waste management
- Telecommunication
- Public transport



- Oil and gas
- Pharmaceutical
- Automotive
- Pulp and paper



- Energy distribution
- Power generation
- Public services



# InLine II overview

A wide portfolio to meet your installation's requirements



ZLBM 00-100 mm  
160 A

ZLBM / ZHBM 00/123-185  
160 - 630 A

ZLBM 800 / 1250 A  
800 / 1250 A

BZL1250A / 2000 A  
1250 / 2000 A

Fuse switch disconnecter

Switch disconnecter  
(Delivered with factory mounted solid links)



ZHBM2-T/ZHBM3-T/  
BZH2000A-T/ BZH1600-S-T-MB

ITS2.1

Cu+ range  
for higher ambient temperatures

Digital enabled products

# InLine II

## Robust and reliable switching and protection

InLine II keeps your electrical distribution system running and your people safe. Its superior performance and smart design enable a flexible and efficient installation, and allow easy and safe operation and maintenance in any application.



### High performance

- Ratings up to 1000 V AC
- Short circuit protection up to 120 kA
- Range for high temperatures available. InLine II Cu+ versions are designed for high ambient temperatures, up to 55°C (131°F) without derating
- Integrated ventilation channel for optimized cooling



### Safety and protection

- Easy and safe access to fuse contacts for voltage measuring and replacement of NH fuse links
- Possibility for padlocking to avoid unauthorized operation
- Sealing facilities available to indicate unauthorized access
- The degree of protection is IP30 (front)
- IP20 touch proof Z-busbar system available

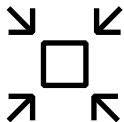

### Convenience and ease

- Available in two different versions, with different depths: ZLBM for space saving and ZHBM for easy integration of current transformers at the back
- Wide variety of cable terminals – Bolts or V-Clamps – enables a flexible installation and makes it possible to customize the product according to your needs
- Cable up or down solution with the same switch
- Suitable for vertical and horizontal installations



### Continuous operation

- Electronic Fuse Monitoring (EFM) raises an alert in the event of a blown fuse.
- ITS2 intelligent monitoring unit for cloud-based connectivity with ABB Ability™ Energy and Asset Manager and enhanced safety features
- Preventive overload protection – adjust time and current thresholds



# High performance

## Ready to meet current and future requirements

### Robust operation in a wide variety of applications

Available as 160A, 250A, 400A and 630A types in combination with NH/DIN HRC Fuse Links according to EN/IEC 60269. InLine II has been type tested in accordance to EN/IEC 60947-3. The variants BZL and BZH have current ratings up to 2500 Amperes.



### Ready for high voltage trends

InLine II provides safe and reliable switching and protection for demanding applications such as photovoltaic installations and battery energy storage systems. The rated voltages are up to 1000 V AC, AC-22B utilization category, with a rated operational current of up to 630 A. The short circuit protection level is up to 120 kA.

Up to

**1000 V AC**  
ratings, utilization  
category AC-22B

Short circuit  
capacity up to

**120 kA**  
for fuse switch disconnectors

800 V AC Fusegear



### Reliable in extreme conditions

The InLine II Cu+ variants have been designed for use in installations with ambient temperature up to 55°C (131°F), without derating.

The newest BZH1600A-S-T-3P-MB is a single switch disconnecter rated to withstand short circuits up to 40 kA, 1s, using 27% less width compared to alternative solutions.

Suitable for  
temperatures up to  
**55°C (131°F)**  
without derating

### Designed to keep cool

InLine II has been designed to give the most optimized ventilation of the switches to prevent overheating. An integrated ventilation channel at the side of the body will also support the air ventilation upwards between the switches when they are installed side by side.

InLine II Cu+ for high ambient temperatures



# Safety and protection

## Inbuilt safety features

### Easy access for voltage measurement

Voltage can be measured safely using standard equipment. The front windows can be slid upwards, allowing easy and safe access to the NH fuse contacts.

### Padlocking and sealing

The open position can be locked with up to two padlocks.

To prevent unauthorized access, the front covers of the ZLBM/ZHBM 1-pole variants can be placed in park position with the possibility to be padlocked without additional accessories. The padlock hasp can also be used in this position when up to 3 padlocks per phase are required. Sealing facilities are also available to guarantee highest safety level by indicating unauthorized access.

### Degree of protection IP30

InLine II fuse switch disconnectors have an ingress protection degree of IP30 from the front in closed and IP20 in open position.

### Safe and easy replacement of fuses

InLine II is designed for an easy and safe replacement of NH fuse links. The designated replacement position minimizes the risk of contact with live parts.



— Padlock in open position

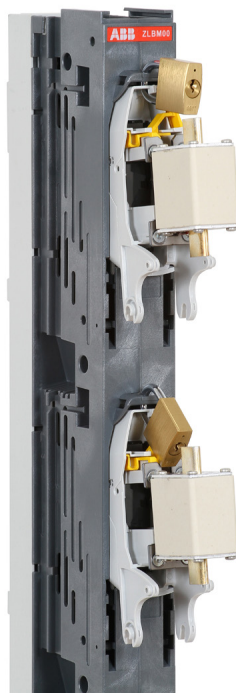

— Padlock in park position



— Padlock extension



— Padlock in closed position

# Safety and protection

## Easy and safe replacement of fuses



ON – Closed position



OFF – Open position

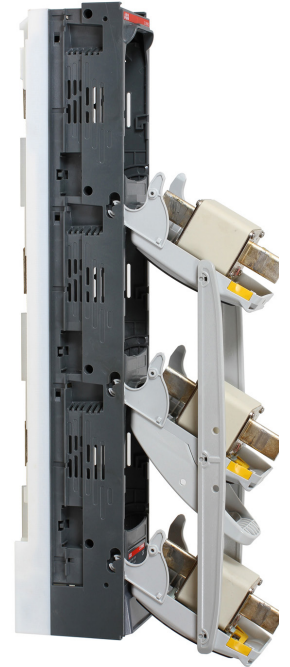

Replacement of fuses position



Release button

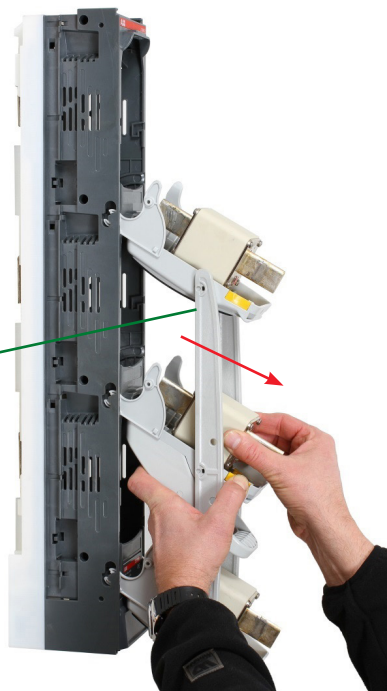

Replacement of fuses

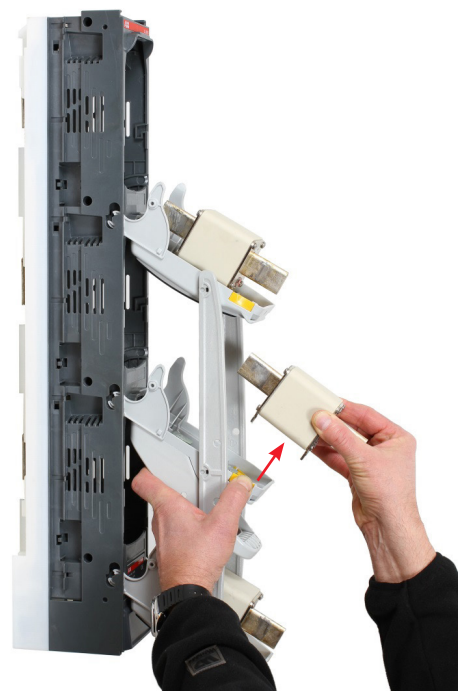



## Convenience and ease

### Easy and flexible installation

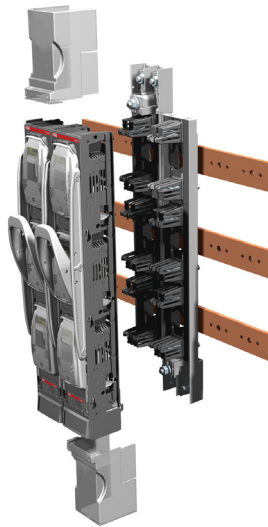

#### Designed for different busbar systems

The ZLBM size 00-100 is suitable for 100 mm busbar systems. The rest of the variants are suitable for installation at busbars with 185 mm distance.

#### Designed for

**100 and 185 mm**  
busbar systems

#### Fast and easy mounting on flat busbars

A selected variety of switches are now available with integrated hook clamps. Hook clamps are also available as separate accessories for all ZLBM versions.

— Symmetric front position independent of the cable terminations are UP or DOWN



— Hook clamps

#### Easy connection for all types of cables

Variants with integrated V-Clamps and universal terminal bolts make the connection easy for all types of cables. The ZLBM/ZHBM sizes 1, 2 and 3 are delivered with standing M12 Bolts at the cable terminals as standard. The nut and the bolt can easily be exchanged if there is a need to insert the M12 Bolt from the front. The ZLBM/ZHBM versions sizes 00, 1, 2 and 3 can be delivered with integrated V-Clamps.

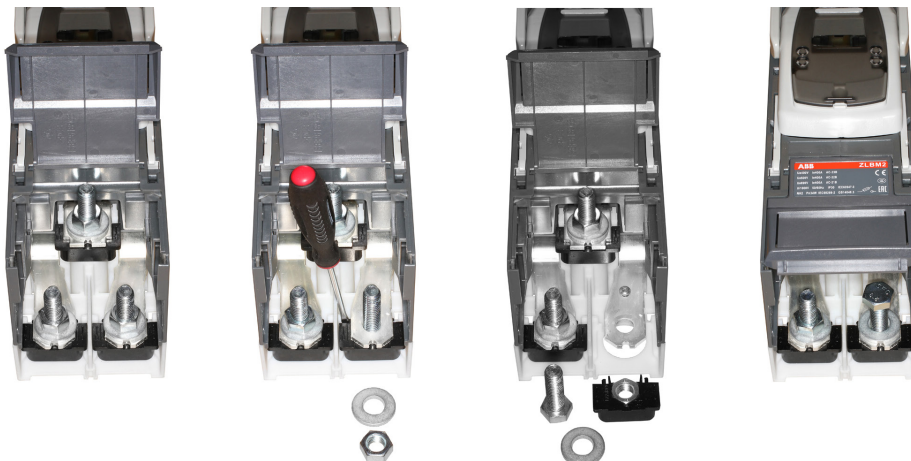

— Universal terminal Bolts

## Convenience and ease

### Save space and installation time

#### Space saving

There are two versions of InLine II, with different depths that can be selected according to application requirements and available space. The ZLBM versions with reduced depth of 121 mm are suitable for Cable Distribution Cabinets. The ZLBM versions generate up to 20% savings in panel depth, and have 47% less depth compared to alternative solutions in the market.

The ZHBM versions with 154 mm depth enable easy integration of current transformers (CT) at the back side. It is possible to slide one current transformer per phase.

#### Faster, tool-less installation of current transformers

The current transformers (CT) in ZHBM variants have been especially designed to be slid on the back and locked on place with snap-on shrouds. The CT shrouds have integrated cable channels for easy cable supply up to a multi plug for external connection.

#### Speed up your project

A selected variety of In Line II switches can be delivered in bulk packages. With the bulk packaging, you can save up to two minutes of unpacking per switch.



The ZHBM 00/123 variants make it possible to slide on one current transformer (CT) at the rear side per phase

## Continuous operation

### Real time monitoring and easy serviceability



Monitor in real time



Ease serviceability



Minimize downtime

#### Electronic Fuse Monitoring functionality (EFM)

This functionality monitors operational status and, in the event of a blown fuse, raises an alert. It allows easy location of faults, enhancing safety, serviceability and minimizing downtime. The electronic fuse monitoring unit is integrated in InLine II.

#### Smarter, data-driven decisions made in real time

InLine II can have an integrated ITS2 monitoring unit. ITS2 enables cloud-based connectivity via ABB Ability™ Energy and Asset Manager, making it easy to monitor key electrical parameters in real-time and allowing users to optimize their networks simply and safely.

The ITS2 monitoring unit also includes EFM functionality and preventive overload protection.

The preventive overload protection feature makes it possible to configure time and current thresholds, increasing the level of protection in the system. This can be done in less than 1 minute using Ekip Connect.





# Electronic Fuse Monitoring

## Real time monitoring and easy serviceability

The Electronic Fuse Monitor (EFM) gives a remote alarm at any fault conditions if a fuse is blown and allows faults to be located quickly.

- The EFM unit is self-supplied, which means no additional power supply is required
- The EFM functionality is available up to 800 V AC
- The fuse status is also visible on the product, with red and green LEDs



InLine II with Electronic Fuse Monitor (EFM)

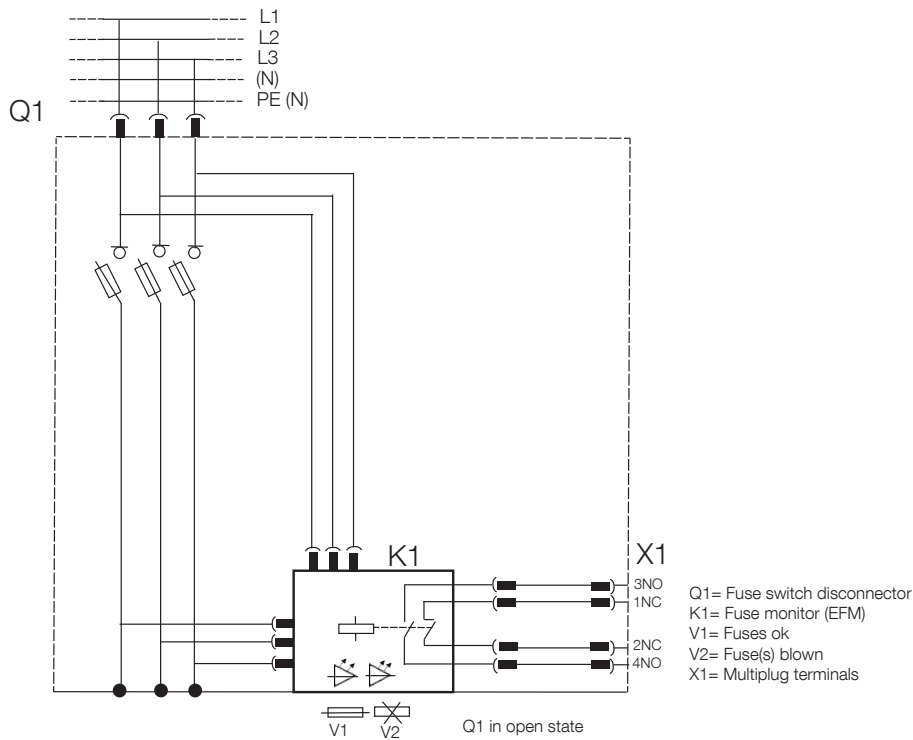

Fuse status	Green LED	Red LED	Relay contacts		Relay contacts	
			NO contact 11,12		NC contact 13,12	
			Open	Closed	Open	Closed
<b>1. ON position</b>						
Fuses OK	★	●	X			X
Fuses BLOWN	●	★		X	X	
<b>2. OFF position</b>						
Fuses OK	●	●	X			X
Fuses BLOWN	●	●	X			X

# ITS2 monitoring unit

## Inside knowledge that puts you ahead

Real-time measuring and monitoring have never been easier, thanks to the ITS2. Its built-in intelligence means that whether it is supporting a data center, hospital or commercial building, operatives can access its monitoring data and provide an instant response in the event of any system faults.

**The result of this fully digital solution? Smarter, data-driven decisions made in real time.**



### Integrated and future-ready

- Cloud-based connectivity with ABB Ability™ Energy and Asset Manager
- Easy configuration with Ekip Connect
- Configure ITS2 monitoring in just 1 min

Configure in less than

**1 minute**  
with Ekip Connect

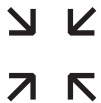

### Convenience and ease

- One unit to digitalize switches and fusegear also compatible with OT switch disconnectors and OS Switch fuses
- Space-saving factory mounted design
- 80% faster installation

Full control in less than

**10 minutes**



### Safe and reliable

- Ensures continuous operations
- Fuse monitoring functionality (EFM)
- System safety and protection protocols
- Increases the level of protection in the electrical system (Preventive Overload Protection)



# ITS2 monitoring unit

## Connection to ABB Ability™ Energy and Asset Manager

### InLine II ITS2 Modbus RTU

- - - Ethernet cable
- Modbus RTU
- Power

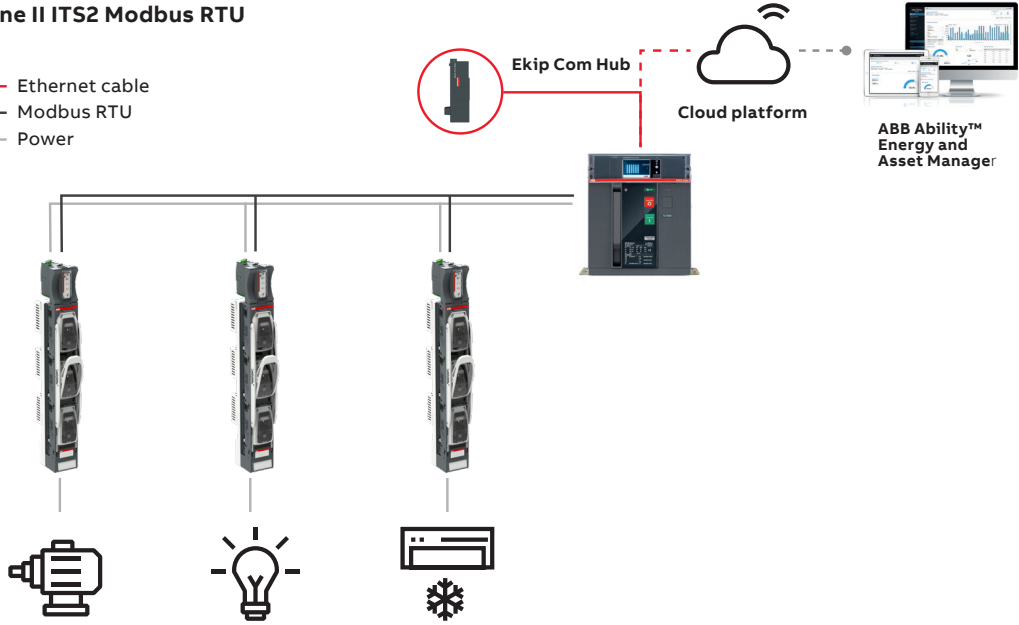

### InLine II ITS2 TCP module

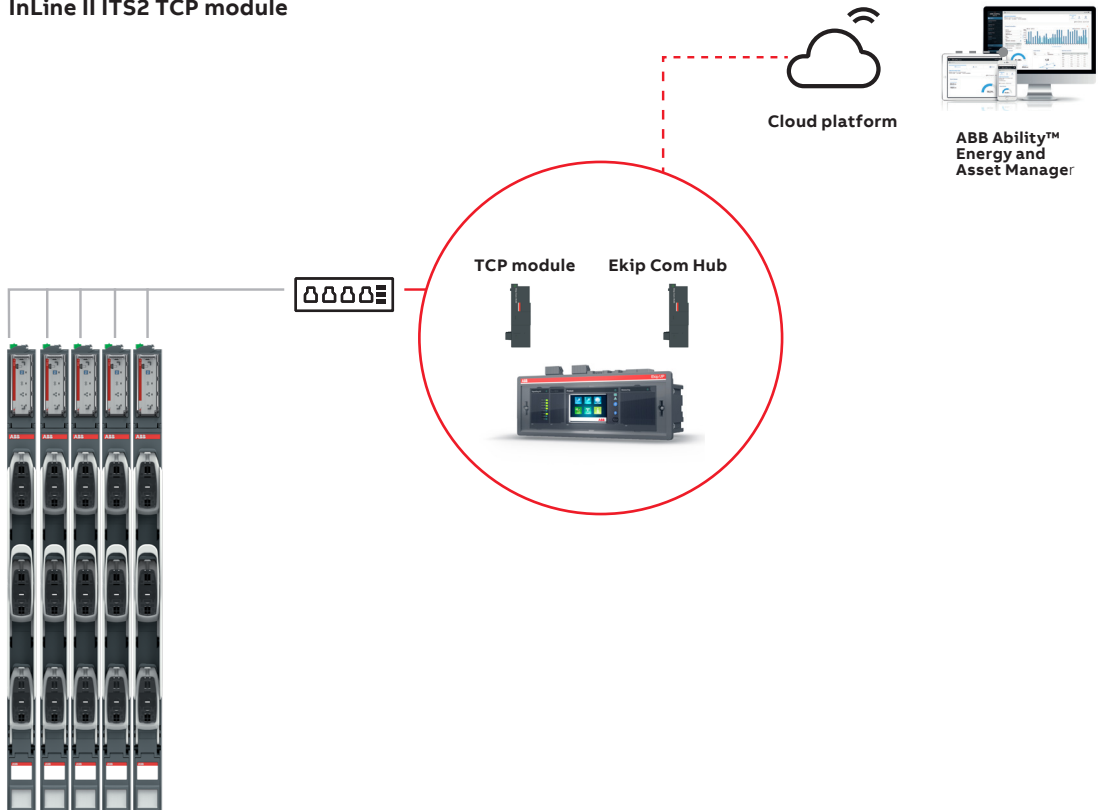



# Overview of product range

## Type codes and product configuration table

Understanding the type code keys below will help you quickly identify the correct product for your needs. The simple naming system allows you to see the products type, ampere rating, standard classification and number of poles, all in one glance.

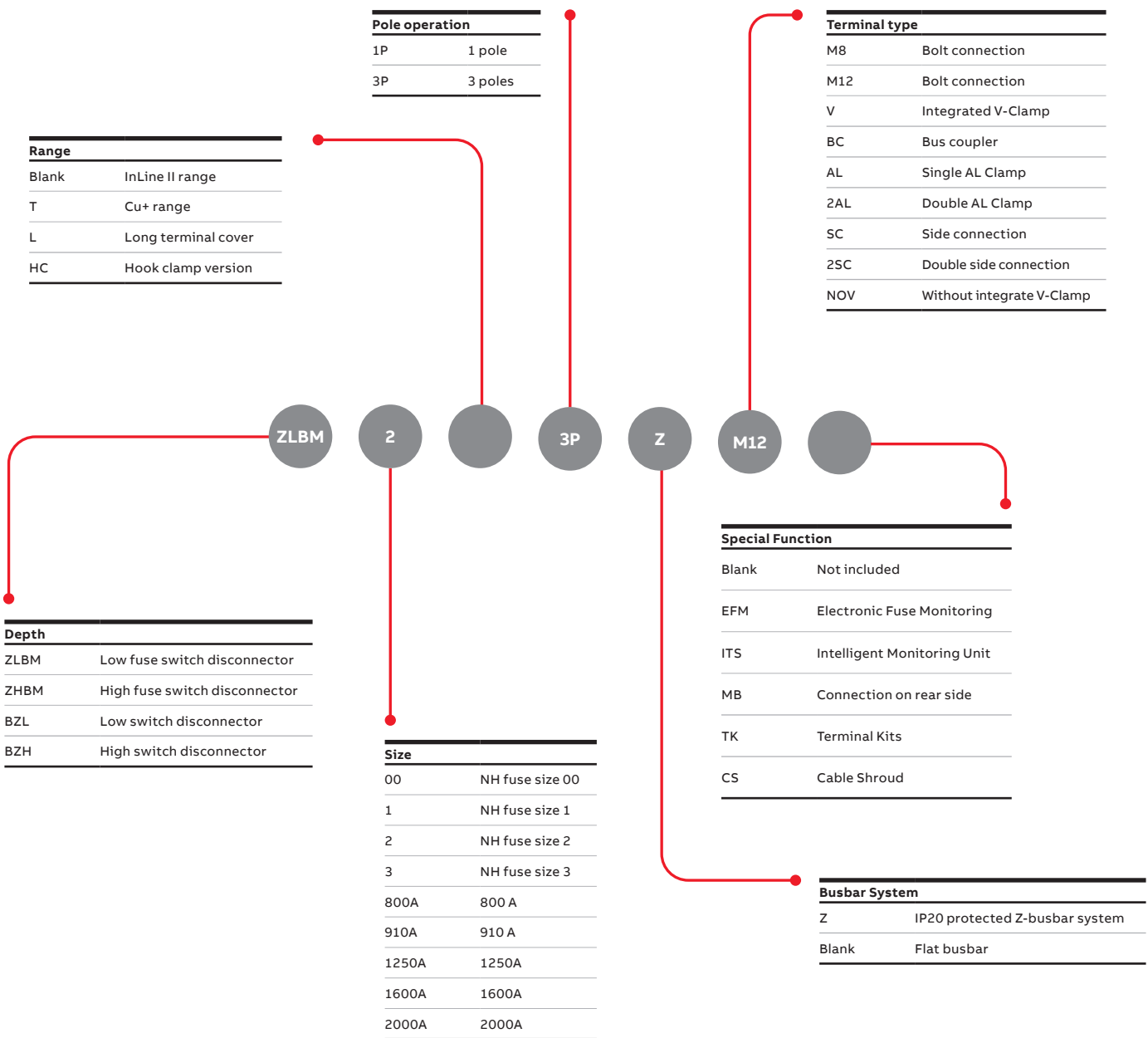

# Technical data

## ZLBM/ZHBM Fuse switch disconnectors

		ZLBM 00-100	ZLBM 00 / ZHBM 00	ZLBM / ZHBM 1	ZLBM / ZHBM 2	ZLBM / ZHBM 3	
For NH fuse links acc. to IEC60269-2		00	00	1	1/2	3	
Rated operational voltage U <sub>e</sub> .	(V AC)	Tested with gG fuse	500 / 690 / 800	400 / 500 / 690	400 / 500 / 690	400 / 500 / 690	400 / 500 / 690
		Tested with gS fuse	800	-	800	800	800
		Tested with aR fuse	-	1000	1000	1000	1000
Rated operational current I <sub>e</sub> .	(A)	Tested with gG fuse	160 / 125 / 63	160 / 160 / 125	250	400, 250 (NH1)	630
		Tested with gS fuse	125	-	200	400	400
		Tested with aR fuse	-	125	250	400	630
Rated insulation voltage U <sub>i</sub> .	(V AC)	1000	1000	1000	1000	1000	
Rated impulse withstand voltage U <sub>imp</sub> .	(kV)	8	8	8	8	8	
Fuse protected short circuit withstand current	(kArms)	Tested with gG fuse	100 / 100 / 50	100 / 100 / 100	100 / 100 / 100	100 / 100 / 100	100 / 100 / 100
		Tested with gS fuse	120	-	100	100	50
		Tested with aR fuse	-	120	120	120	120
Fuse protected short circuit making.	(kArms)	Tested with gG fuse	100 / 100 / 50	100 / 100 / 100	100 / 100 / 100	100 / 100 / 100	100 / 100 / 100
		Tested with gS fuse	120	-	100	100	50
		Tested with aR fuse	-	120	120	120	120
Rated making and breaking capacity	400 V AC	-	AC-23B	AC-23B	AC-23B	AC-23B	
	500 V AC	AC-23B	AC-22B	AC-22B	AC-22B	AC-22B	
	690 V AC	AC-22B	AC-21B	AC-21B	AC-21B	AC-21B	
	800 V AC	AC-22B	-	AC-22B	AC-22B	AC-22B	
	1000 V AC	-	AC-22B	AC-22B	AC-22B	AC-22B	
Rated frequency	(Hz)	50/60	50/60	50/60	50/60	50/60	
Total power loss at I <sub>th</sub>	(W)	33,4	33,6	37,8	55,50	97,20	
Degree of protection from the front.	Open	IP20	IP20	IP20	IP20	IP20	
	Closed	IP30	IP30	IP30	IP30	IP30	
Electrical durability, operating cycles -		200	200	200	200	200	
Mechanical durability, operating cycles -		1400	1400	1400	800	800	

Type tested according to EN/IEC 60947-3

# Technical data

## ZLBM/ZHBM/BZL/BZH

		ZLBM/ZHBM800	ZLBM/ZHBM1250	ZLBM910A	BZL/ BZH1250A	BZL/ BZH2000A
For NH fuse links acc. to IEC60269-2		2	3	3	-	-
Rated operational voltage Ue.	(V AC)	500	500	400	690 / 500	690 / 500
Rated operational current Ie.	(A)	800	1250	910	1250	2000
Rated insulation voltage Ui.	(V AC)	1000	1000	1000	1000	1000
Rated impulse withstand voltage Uimp.	(kV)	8	8	8	8	8
Fuse protected short circuit withstand current	(kArms)	100	100	25	-	-
Fuse protected short circuit making.	(kArms)	100	100	25	-	-
Short-time withstand current – 1sec (rms)	(kA)	-	-	-	20 kA (3P) 15 kA (1P)	30 kA
Short-circuit making capacity (peak)	(kA)	-	-	-	20	30
	400 V AC	-	-	AC-22B	-	-
Rated making and breaking capacity	500 V AC	AC 21B	AC 21B	-	AC-22B	AC-22B
	690 V AC	-	-	-	AC-21B	AC-21B
Rated frequency	(Hz)	50 / 60	50 / 60	50 / 60	50 / 60	50 / 60
Total power loss at Ith	(W)	139,7	270	179,4	292,2	594,9
Max permis. Power loss pr fuse link	Pv (W)	34	48	69	-	-
Degree of protection from the front.	Open	IP20	IP20	IP20	IP20	IP20
	Closed	IP30	IP30	IP30	IP30	IP30
Electrical durability, operating cycles	-	100	100	100	100	100
Mechanical durability, operating cycles	-	500	500	500	500	500

Type tested according to EN/IEC 60947-3

The ambient air temperature must not exceed 40°C and its average over a period of 24h must not exceed 35°C



# Technical data

## ZLBM/ZHBM/BZL/BZH bus coupler

		ZLBM2-BC	ZLBM3-BC	BZH1000A- BC	BZH1250A- BC	BZH1600A- BC	BZH2000A- BC
For NH fuse links acc. to EN/IEC 60269-2		2	3	-	-	-	-
Rated operational current I <sub>e</sub>	(A)	400	630	1000	1250	1600	2000
Conventional free air thermal current I <sub>th</sub>	(A)	400	630	1000	1250	1600	2000
Rated operational voltage U <sub>e</sub>	(V AC)	500/690	500/690	690	690	690	690
Rated insulation voltage U <sub>i</sub>	(V AC)	1000	1000	1000	1000	1000	1000
Rated impulse withstand voltage U <sub>imp</sub>	(kV)	8	8	8	8	8	8
Fuse protected short circuit withstand current	(kA)	120/100	120/100	-	-	-	-
Fuse protected short circuit making current	(kA)	120/100	120/100	-	-	-	-
Short-time withstand current – 1sec (rms)	(kA)	-	-	15	15	30	30
Short-circuit making capacity (peak)	(kA)	-	-	15	15	30	30
Utilization category – EN/IEC 60947-3	-	AC 22B	AC 22B	AC 22B	AC 22B	AC 21B	AC 21B
Mechanical durability, operating cycles	-	800	800	500	500	500	500
Electrical durability, operating cycles	-	200	200	100	100	100	100
Degree of protection IEC 60529	Close	IP30	IP30	IP30	IP30	IP30	IP30
	Open	IP20	IP20	IP20	IP20	IP20	IP20
Pollution degree	-	3	3	3	3	3	3
Overvoltage category – IEC 60947-1	-	IV	IV	IV	IV	IV	IV
Rated frequency	(Hz)	50/60	50/60	50/60	50/60	50/60	50/60
Total power loss at I <sub>th</sub>	(W)	34,6	62,8	65,2	65,2	141	141
Universal terminal bolt size	-	M12	M12	M12	M12	M12	M12
Terminal tightening torque	Nm	25	25	35	35	35	35

Note: 1) The solid links are included in the product  
Type tested according to EN/IEC 60947-3

The ambient air temperature must not exceed 40°C and its average over a period of 24h must not exceed 35°C

# Technical data

## InLine II Cu+

	ZHBM2-T	ZHBM3-T	ZHBM1250-T	BZH1000A-T	BZH1600A-T	BZH2000A-T	BZH1600A-S-T-3P-MB
For NH fuse links acc. to IEC60269-2	1/2	3	3	-	-	-	-
Single switch/ double switch	Single	Single	Double	Single	Double	Double	Single
Rated operational voltage U <sub>e</sub> . (V AC)	400/500/690	400/500/690	500	690	690	500/690	690
Rated operational current I <sub>e</sub> . (A)	400	630	1250	1000	1600	2000	1600
Rated insulation voltage U <sub>i</sub> . (V AC)	1000	1000	1000	1000	1000	1000	1000
Rated impulse withstand voltage U <sub>imp</sub> . (kV)	8	8	8	8	8	8	8
Fuse protected short circuit withstand current (kArms)	100	100	100	-	-	-	-
Rated short time withstand current 1 sec. (kArms)	-	-	-	15 (1P)	30	30	40
Rated making and breaking capacity	400 V AC	AC-23B	AC-23B	-	-	-	-
	500 V AC	AC-22B	AC-22B	AC-21B	-	AC-22B	-
	690 V AC	AC-21B	AC-21B	-	AC-22B	AC-21B	AC-20B
	800 V AC	-	-	-	-	-	-
Rated frequency (Hz)	50/60	50/60	50/60	50/60	50/60	50/60	50/60
Total power loss at I <sub>th</sub> , incl. Terminal kit (W)	70,4	122,9	412,8	183,8	288,9	367,6	-
Total power loss at I <sub>th</sub> (W)	57,8	102,9	654,9	253,3	516,2	597,9	300,0
Max permis. power loss per fuse link P <sub>v</sub> (W)	34	48	48	-	-	-	-
Degree of protection from the front.	Open	IP20	IP20	IP20	IP20	IP20	IP20
	Closed	IP30	IP30	IP30	IP30	IP30	IP30
Electrical durability, operating cycles	-	200	200	100	100	100	100
Mechanical durability, operating cycles	-	800	800	500	500	500	500
Max. cable cross section to be connected (mm <sup>2</sup> )	240	240	-	240	-	-	2x300
Max. cable cross section to be connected splice for two parallel cables (mm <sup>2</sup> )	2x240	2x240	4x240	2x240	4x240	4x240	-

Type tested according to EN/IEC 60947-3

The ambient air temperature must not exceed 55°C and its average over a period of 24h must not exceed 50°C

# Technical data

## Derating tables

InLine II is a technically reliable and proven solution for demanding conditions

### Ambient temperatures for switches

The working ambient temperatures for the general range lays in between -25°C up to 40°C, considering no derating to be applied. The InLine II Cu+ range can withstand ambient temperatures up to 55°C without derating.

Derating table for general range

Ambient temperature in °C	Ith % of nominal current	Ith % of nominal current with EFM
40*	100	100
45	95	92
50	90	84
55	85	75
60	80	66
65	75	56
70	69	44
75	63	29

\*The ambient air temperature must not exceed 40 °C and its average over a period of 24h must not exceed 35 °C

Derating table for general range for InLine II Cu+

Ambient temperature in °C	Ith % of nominal current	Ith % of nominal current for BZH1600A-S-T-3P-MB
55*	100	94
60	95	89
65	90	83
70	85	76
75	80	70

\*The ambient air temperature must not exceed 55°C and its average over a period of 24h must not exceed 50°C



—  
02

## Ordering information

## Ordering information

<b>Fuse switch disconnectors ZLBM</b>	
ZLBM, 1-pole, depth 121 mm	26
ZLBM, 1-pole, depth 121 mm	27
ZLBM, 3-pole, depth 121 mm	28
ZLBM, 3-pole, with Electronic Fuse Monitoring (EFM)	31
<b>Fuse switch disconnectors ZHBM</b>	
ZHBM, 1-pole, depth 154 mm	32
ZHBM, 3-pole, depth 154 mm	33
ZHBM, 3 poles with Electronic Fuse Monitoring (EFM)	35
ZHBM, 3-poles with ITS2.1 monitoring unit	36
InLine II Cu+ for high ambient temperatures, 1 and 3 poles	37
<b>Switch disconnectors</b>	
BZL and BZH switch disconnectors	39
<b>Bus couplers</b>	
Bus couplers	40
<b>Z-busbar system</b>	
ZLBM, 1- and 3-pole with IP20 touch proof Z-busbar system	41
ZLBM, 1- and 3-pole with IP20 touch proof Z-busbar system	42
400 A & 630 A Z-busbar system	43
1600 A & 2500 A Z-busbar system	45
<b>Accessories</b>	
Accessories IP20 Z-busbars	47
Accessories for ZLBM00 and ZHBM00	48
Accessories - Ammeter and current transformers for ZLBM00 and ZHBM00	49
Accessories - Current transformers for ZHBM00	50
Accessories for ZLBM1/2/3 and ZHBM1/2/3	51
Accessories - Current transformers for ZLBM1/2/3 and ZHBM1/2/3	52
Ammeter for ZLBM1/2/3 and ZHBM1/2/3	54
<b>Quick selection</b>	
Cable terminations and shrouds for ZLBM00-100	55
Cable terminations and shrouds for ZLBM1/2/3 and ZHBM1/2/3	56
Cable terminations and shrouds for BZL and BZH	58

# Ordering information

## ZLBM, 1-pole, depth 121 mm



ZLBM00-1P

### Single switch, M8, M12 Bolt or V-Clamp cable connection

Fuse size	Rated operational current I <sub>e</sub> [A]	Type	Description	Order code	Weight (Kg)
NH00	160	ZLBM00-1P-M8	3 x M8 Bolts	1SEP620010R1000	1,75
NH00	160	ZLBM00-1P-V	3 x V-Clamps, NHSN722079P0001**	1SEP620010R1020	1,9
NH1	250	ZLBM1-1P-M12	3 x M12 Universal Bolts	1SEP620011R1000	3,56
NH1	250	ZLBM1-1P-V	3 x V-Clamps, NHSN722066P0003**	1SEP620011R1020	3,56
NH1, NH2	400	ZLBM2-1P-M12	3 x M12 Universal Bolts	1SEP620012R1000	4,04
NH1, NH2	400	ZLBM2-1P-V	3 x V-Clamps, NHSN722066P0003**	1SEP620012R1020	4,02
NH2*, NH3	630	ZLBM3-1P-M12	3 x M12 Universal Bolts	1SEP620013R1000	4,65
NH2*, NH3	630	ZLBM3-1P-V	3 x V-Clamps, NHSN722066P0003**	1SEP620013R1020	4,65

\* with dedicated adapter only, ZLBM3 NH2 fuse adapter – 1SEP621288R0001

\*\*see section "Quick selection" for more information



ZLBM1/2/3-1P

### 800A version, double switch, M12 Bolt or V-Clamp cable connection

Fuse size	Rated operational current I <sub>e</sub> [A]	Type	Description	Order code	Weight (Kg)
NH1, NH2	800	ZLBM800A-1P-M12	12 x M12 Universal Bolts	1SEP620014R1000	11,2



ZLBM800A-1P-M12

### 910A version, single switch, for LV side of 630kV transformer, M12 Bolt cable connection

Fuse size	Rated operational current I <sub>e</sub> [A]	Type	Description	Order code	Weight (Kg)
NH2*, NH3	910	ZLBM910A-1P-M12	2 x 3 M12 Universal Bolts	1SEP620053R1000	9,3

\* with dedicated adapter only, ZLBM3 NH2 fuse adapter – 1SEP621288R0001



ZLBM910A-1P-M12

# Ordering information

## ZLBM, 1-pole, depth 121 mm



ZLBM1/2/3-L-3P-3U

### Long terminal cover for extra touch prevention on cable connection, single switch, 3x U-shaped busbar versions

Fuse size	Rated operational current I <sub>e</sub> [A]	Type	Description	Order code	Weight (Kg)
NH00	160	ZLBM00-1P-3U-M8	3 x M8 Bolts, 3x elliptical shaped holes on busbar connection	1SEP620170R1200	1,75
NH1	250	ZLBM1-L-1P-3U-M12		1SEP620171R1200	3,56
NH1, NH2	400	ZLBM2-L-1P-3U-M12	3 x M12 Universal Bolts, 3x U-shaped holes on busbar connection, long	1SEP620172R1200	4,04
NH2*, NH3	630	ZLBM3-L-1P-3U-M12	terminal cover	1SEP620173R1200	4,65

\* with dedicated adapter only, ZLBM3 NH2 fuse adapter – 1SEP621288R0001

### V-Clamp cable terminals, V-Clamp not included, single switch

Fuse size	Rated operational current I <sub>e</sub> [A]	Type	Description	Order code	Weight (Kg)
NH00	400	ZLBM2-1P-NOV	Delivery with V-Clamp cable terminals but without V-Clamps. Own choice of clamps can be installed	1SEP622417R0001	4,12



# Ordering information

## ZLBM, 3-pole, depth 121 mm



ZLBM00-100

### Single switch, 100 mm busbar distance, M8 cable connection

Fuse size	Rated operational current I <sub>e</sub> [A]	Type	Description	Order code	Weight (Kg)
NH00	160	ZLBM00-100-3P-M8	3 x M8 Bolts, cable shroud included	1SEP620150R3000	1,04
NH00	160	ZLBM00-100-3P-M8 100 pcs on pallet	3 x M8 Bolts, 100 pcs. bulk on euro pallet	1SEP620150R8000	0,98*

\*weight per individual fuse switch disconnecter



ZLBM00

### Basic versions, single switch, M8, M12 or V-Clamp cable connection

Fuse size	Rated operational current I <sub>e</sub> [A]	Type	Description	Order code	Weight (Kg)
NH00	160	ZLBM00-3P-M8	3 x M8 Bolts	1SEP620010R3000	1,82
NH00	160	ZLBM00-3P-V	3 x V-Clamps, NHSN722079P0001*	1SEP620010R3020	1,97
NH1	250	ZLBM1-3P-M12	3 x M12 Universal Bolts	1SEP620011R3000	3,63
NH1	250	ZLBM1-3P-V	3 x V-Clamps, NHSN722066P0003*	1SEP620011R3020	3,64
NH1, NH2	400	ZLBM2-3P-M12	3 x M12 Universal Bolts	1SEP620012R3000	4,13
NH1, NH2	400	ZLBM2-3P-V	3 x V-Clamps, NHSN722066P0003*	1SEP620012R3020	4,12
NH2*, NH3	630	ZLBM3-3P-M12	3 x M12 Universal Bolts	1SEP620013R3000	4,73
NH2*, NH3	630	ZLBM3-3P-V	3 x V-Clamps, NHSN722066P0003*	1SEP620013R3020	4,72

\* with dedicated adapter only, ZLBM3 NH2 fuse adapter – 1SEP621288R0001

\*\*see section "Quick selection" for more information

### Single switch, M8, M12 or V-Clamp cable connection, including hook clamps

Clamps for hooked mounting on flat busbar systems. Suitable for 5mm and 10 mm busbar thickness.

Fuse size	Rated operational current I <sub>e</sub> [A]	Type	Description	Order code	Weight*** (Kg)
NH00	160	ZLBM00-HC-3P-M8	3 x M8 Universal Bolts, hook clamps pre-installed	1SEP622761R0001	2,03
NH00	160	ZLBM00-HC-3P-V	3 x V-Clamps, NHSN722079P0001, hook clamps pre-installed**	1SEP622762R0001	2,18
NH1	250	ZLBM1-HC-3P-V		1SEP622763R0001	3,92
NH1, NH2	400	ZLBM2-HC-3P-V		1SEP622764R0001	4,3
NH2*, NH3	630	ZLBM3-HC-3P-V	3 x V-Clamps, NHSN722066P0003, hook clamps pre-installed**	1SEP622765R0001	5
NH2*, NH3	630	ZLBM3-HC-3P-M12-42pcs	3 x M12 Universal Bolts, hook clamps pre-installed, 42 pcs. bulk on euro pallet	1SEP622760R0001	4,89 ***
NH2*, NH3	630	ZLBM3-HC-3P-M12	3 x M12 Universal Bolts, hook clamps pre-installed	1SEP622472R0001	5,01

\*with dedicated adapter only, ZLBM3 NH2 fuse adapter – 1SEP621288R0001

\*\*see section "Quick selection" for more information

\*\*\*weight per individual fuse switch disconnecter

# Ordering information

## ZLBM, 3-pole, depth 121 mm



ZLBM910A-3P-M12



ZLBM910A-3P-M12-MB

### 800A version, double switch, M12 Bolt or V-Clamp cable connection

Fuse size	Rated operational current I <sub>e</sub> [A]	Type	Description	Order code	Weight (Kg)
NH2	800	ZLBM800A-3P-M12	12 x M12 Universal Bolts	1SEP620014R3000	11,1
NH2	800	ZLBM800A-3P-V	12 x V-Clamps, NHSN722066P0003*	1SEP620014R3020	11,3

\*see section "Quick selection" for more information

### 910A version, double switch, for LV side of 630kV transformer, M12 Bolt cable connection

Fuse size	Rated operational current I <sub>e</sub> [A]	Type	Description	Order code	Weight (Kg)
NH3	910	ZLBM910A-3P-M12	2 x 3 M12 Universal Bolts	1SEP620053R3000	9,5
NH3	910	ZLBM910A-3P-M12-MB	2 x 3 M12 Universal Bolts, terminal connection on rear side	1SEP620053R3050	7,3

### 1250A version, double switch, M12 Bolt or V-Clamp cable connection

Fuse size	Rated operational current I <sub>e</sub> [A]	Type	Description	Order code	Weight (Kg)
NH3	1250	ZLBM1250A-3P-M12	12 x M12 Universal Bolts	1SEP620015R3000	12,25
NH3	1250	ZLBM1250A-3P-V	12 x V-Clamps, NHSN722066P0003*	1SEP620015R3020	12,5

\*see section "Quick selection" for more information

# Ordering information

## ZLBM, 3-pole, depth 121 mm



ZLBM1/2/3-L-3P-3U

### Single switch, V-Clamp cable terminals, V-Clamp not included

Fuse size	Rated operational current I <sub>e</sub> [A]	Type	Description	Order code	Weight (Kg)
NH00	160	ZLBM00-3P-NOV		1SEP620010R3010	1,97
NH1	250	ZLBM1-3P-NOV		1SEP620011R3010	3,63
NH1, NH2	400	ZLBM2-3P-NOV	Delivery with V-Clamp cable terminals but without V-Clamps. Own choice of clamps can be used**	1SEP620012R3010	4,12
NH2*, NH3	630	ZLBM3-3P-NOV		1SEP620013R3010	4,72

\* with dedicated adapter only, ZLBM3 NH2 fuse adapter – 1SEP621288R0001

\*\*see section "Quick selection" for more information

### Long terminal cover for extra touch prevention on cable connection, single switch, 3x U-shaped busbar versions

Fuse size	Rated operational current I <sub>e</sub> [A]	Type	Description	Order code	Weight (Kg)
NH00	160	ZLBM00-3P-3U-M8	3 x M8 Bolts, 3x elliptical shaped holes on busbar connection	1SEP620170R3200	1,82
NH1	250	ZLBM1-L-3P-3U-M12		1SEP620171R3200	3,63
NH1, NH2	400	ZLBM2-L-3P-3U-M12	3 x M12 Universal Bolts, 3x U-shaped holes on busbar connection, long	1SEP620172R3200	4,13
NH2*, NH3	630	ZLBM3-L-3P-3U-M12	terminal cover	1SEP620173R3200	4,73

\* with dedicated adapter only, ZLBM3 NH2 fuse adapter – 1SEP621288R0001

# Ordering information

## ZLBM, 3-pole, with Electronic Fuse Monitoring (EFM)



ZLBM00-EFM



ZLBM1/2/3-EFM

### ZLBM, 3-pole, depth 121 mm, with Electronic Fuse Monitoring (EFM)

The items in this table include a factory mounted EFM. M8, M12 Bolt or V-Clamp cable connection

Fuse size	Rated operational current $I_e$ [A]	Type	Description	Order code	Weight (Kg)
NH00	160	ZLBM00-3P-M8-EFM	3 x M8 Bolts, incl. EFM	1SEP620010R3001	2,02
NH00	160	ZLBM00-3P-V-EFM	3 x V-Clamps, NHSN722079P0001**, incl. EFM	1SEP620010R3021	2,17
NH1	250	ZLBM1-3P-M12-EFM	3 x M12 Universal Bolts, incl. EFM	1SEP620011R3001	3,83
NH1	250	ZLBM1-3P-V-EFM	3 x V-Clamps, NHSN722066P0003**, incl. EFM	1SEP620011R3021	3,84
NH1, NH2	400	ZLBM2-3P-M12-EFM	3 x M12 Universal Bolts, incl. EFM	1SEP620012R3001	4,33
NH1, NH2	400	ZLBM2-3P-V-EFM	3 x V-Clamps, NHSN722066P0003**, incl. EFM	1SEP620012R3021	4,32
NH2*, NH3	630	ZLBM3-3P-M12-EFM	3 x M12 Universal Bolts, incl. EFM	1SEP620013R3001	4,93
NH2*, NH3	630	ZLBM3-3P-V-EFM	3 x V-Clamps, NHSN722066P0003**, incl. EFM	1SEP620013R3021	4,92

\* with dedicated adapter only, ZLBM3 NH2 fuse adapter – 1SEP621288R0001

\*\*see section "Quick selection" for more information



ZLBM00-EFM



ZLBM1/2/3-EFM



# Ordering information

## ZHBM, 1-pole, depth 154 mm



ZHBM00



ZHBM1/2/3



ZHBM3-1P-3U-ST5-M12-CS

### Single switch, M8, M12 Bolt or V-Clamp cable connection

Fuse size	Rated operational voltage U <sub>e</sub> [V]	Rated operational current I <sub>e</sub> [A]	Type	Description	Order code	Weight (Kg)
NH00	1000	160	ZHBM00-1P-M8	3 x M8 Bolts	1SEP620020R1000	1,83
NH00	1000	160	ZHBM00-1P-V	3 x V-Clamps, NHSN722079P0001**	1SEP620020R1020	1,93
NH1	1000	250	ZHBM1-1P-M12	3 x M12 Universal Bolts	1SEP620021R1000	3,6
NH1	1000	250	ZHBM1-1P-V	3 x V-Clamps, NHSN722066P0003**	1SEP620021R1020	3,6
NH1, NH2	1000	400	ZHBM2-1P-M12	3 x M12 Universal Bolts	1SEP620022R1000	4,17
NH1, NH2	1000	400	ZHBM2-1P-V	3 x V-Clamps, NHSN722066P0003**	1SEP620022R1020	4,15
NH2*, NH3	1000	630	ZHBM3-1P-M12	3 x M12 Universal Bolts	1SEP620023R1000	4,74

\* with dedicated adapter only, ZLBM3 NH2 fuse adapter – 1SEP621288R0001

\*\*see section "Quick selection" for more information

### Stainless steel versions with additional plastic cover on the V-Clamp (1SEP622480R0001), single switch

Fuse size	Rated operational voltage U <sub>e</sub> [V]	Rated operational current I <sub>e</sub> [A]	Type	Description	Order code	Weight (Kg)
NH2*, NH3	1000	630	ZHBM3-1P-3U-ST5-M12-CS	3 x M12 Bolts, 1SEP619210R0001 (177mm length) included, 3x U-shaped holes on busbar connection, plastic cover on M12 Bolts	1SEP620174R1000	3,16

\* with dedicated adapter only, ZLBM3 NH2 fuse adapter – 1SEP621288R0001

### Stainless steel versions with additional plastic cover on the V-Clamps, single switch

Fuse size	Rated operational voltage U <sub>e</sub> [V]	Rated operational current I <sub>e</sub> [A]	Type	Description	Order code	Weight (Kg)
NH1, NH2	1000	400	ZHBM2-1P-3U-ST5-V-CS	V-Clamps (1SEP621559R0001)kit incl. , 1SEP619210R0001 (177mm length) included, 3x U-shaped holes on busbar connection, plastic cover on V-Clamps	1SEP622004R0001	2,87
NH2*, NH3	1000	630	ZHBM3-1P-3U-ST5-V-CS	3 x V-Clamps (1SEP621559R0001), plastic cover on V-Clamps	1SEP620178R0001	3,44

\* with dedicated adapter only, ZLBM3 NH2 fuse adapter – 1SEP621288R0001

# Ordering information

## ZHBM, 3-pole, depth 154 mm



ZHBM00



ZHBM1/2/3



ZHBM800A-3P

### Single switch, M8, M12 Bolt or V-Clamp cable connection

Fuse size	Rated operational current I <sub>e</sub> [A]	Type	Description	Order code	Weight*** (Kg)
NH00	160	ZHBM00-3P-M8	3 x M8 Bolts	1SEP620020R3000	1,5
NH00	160	ZHBM00-3P-V	3 x V-Clamps, NHSN722079P0001**	1SEP620020R3020	1,5
NH1	250	ZHBM1-3P-M12	3 x M12 Universal Bolts	1SEP620021R3000	1,67
NH1	250	ZHBM1-3P-V	3 x V-Clamps, NHSN722066P0003**	1SEP620021R3020	1,67
NH1, NH2	400	ZHBM2-3P-M12	3 x M12 Universal Bolts	1SEP620022R3000	2,67
NH1, NH2	400	ZHBM2-3P-V	3 x V-Clamps, NHSN722066P0003**	1SEP620022R3020	2,67
NH2*, NH3	630	ZHBM3-3P-M12	3 x M12 Universal Bolts	1SEP620023R3000	4,81
NH2*, NH3	630	ZHBM3-3P-V	3 x V-Clamps, NHSN722066P0003**	1SEP620023R3020	4,81
NH1, NH2	400	ZHBM2-3P-V -35pcs	3 x V-Clamp 35 pcs. bulk on euro pallet	1SEP622480R0001	2,67 ***

\* with dedicated adapter only, ZLBM3 NH2 fuse adapter – 1SEP621288R0001

\*\*see section "Quick selection" for more information

\*\*\*weight per individual fuse switch disconnecter

### 800A version, double switch, M12 Bolt or V-Clamp cable connection

Fuse size	Rated operational current I <sub>e</sub> [A]	Type	Description	Order code	Weight (Kg)
NH1, NH2	800	ZHBM800A-3P-M12	12 x M12 Universal Bolts	1SEP620024R3000	11,2
NH1, NH2	800	ZHBM800A-3P-V	12 x V-Clamps, NHSN722066P0003*	1SEP620024R3020	11,4

\* with dedicated adapter only, ZLBM3 NH2 fuse adapter – 1SEP621288R0001

### 1250A version, double switch, M12 Bolt or V-Clamp cable connection

Fuse size	Rated operational current I <sub>e</sub> [A]	Type	Description	Order code	Weight (Kg)
NH2*, NH3	1250	ZHBM1250A-3P-M12	12 x M12 Universal Bolts	1SEP620025R3000	12,45
NH2*, NH3	1250	ZHBM1250A-3P-V	12 x V-Clamps, NHSN722066P0003**	1SEP620025R3020	12,65

\* with dedicated adapter only, ZLBM3 NH2 fuse adapter – 1SEP621288R0001

\*\*see section "Quick selection" for more information

# Ordering information

## ZHBM, 3-poles, depth 154 mm



ZHBM00



ZHBM1, ZHBM2, ZHBM3

### Single switch with label holder and cable shroud included

Fuse size	Rated operational current I <sub>e</sub> [A]	Type	Description	Order code	Weight (Kg)
NH1, NH2	400	ZHBM2-3P-M12-LH-CS	3 x M12 Universal Bolt, Label holder (1SEP619214R0001), cable shroud (1SEP619210R0001 - 177mm length)	1SEP622001R0001	3,16
NH1, NH2	400	ZHBM2-3P-V-LH-CS	3 x V-Clamps, NHSN722066P0003*, Label holder (1SEP619214R0001), cable shroud (1SEP619210R0001 - 177mm length)	1SEP622002R0001	2,74
NH2*, NH3	630	ZHBM3-3P-M12-LH-CS	3 x M12 Universal Bolts, Label holder (1SEP619214R0001), cable shroud (1SEP619210R0001 - 177mm length)	1SEP622003R0001	3,34

\* with dedicated adapter only, ZLBM3 NH2 fuse adapter – 1SEP621288R0001

\*\*see section "Quick selection" for more information

### Stainless steel versions with additional plastic cover on the V-Clamps, single switch

Fuse size	Rated operational current I <sub>e</sub> [A]	Type	Description	Order code	Weight (Kg)
NH2*, NH3	630	ZHBM3-3P-V-STS	3 x V-Clamps (1SEP621559R0001) kit included, plastic cover on V-Clamps	1SEP620179R0001	3,62

\* with dedicated adapter only, ZLBM3 NH2 fuse adapter – 1SEP621288R0001

### V-Clamp cable terminals, V-Clamps not included, single switch

Fuse size	Rated operational current I <sub>e</sub> [A]	Type	Description	Order code	Weight (Kg)
NH00	160	ZHBM00-3P-NOV		1SEP620020R3010	1,5
NH1, NH2	400	ZHBM2-3P-NOV	Delivery with V-Clamp cable terminals but V-Clamps not included in the delivery. Own choice of clamps can be used**	1SEP620022R3010	2,33
NH2*, NH3	600	ZHBM3-3P-NOV		1SEP620023R3010	3,34

\* with dedicated adapter only, ZLBM3 NH2 fuse adapter – 1SEP621288R0001

\*\*see section "Quick selection" for more information

# Ordering information

## ZHBM, 3-pole with Electronic Fuse Monitoring (EFM)



ZHBM00-3P-EFM



ZHBM1/2/3-3P-EFM

### ZHBM, 3-pole, depth 154 mm, with Electronic Fuse Monitoring (EFM)

The items in this table include a factory mounted EFM. M8, M12 Bolt and V-Clamp cable connection

Fuse size	Rated operational current $I_e$ [A]	Type	Description	Order code	Weight (Kg)
NH00	160	ZHBM00-3P-M8-EFM	3 x M8 Bolts, incl. EFM	1SEP620020R3001	2,101
NH00	160	ZHBM00-3P-V-EFM	3 x V-Clamps, NHSN722079P0001**, incl. EFM	1SEP620020R3021	2,198
NH1	250	ZHBM1-3P-M12-EFM	3 x M12 Universal Bolts, incl. EFM	1SEP620021R3001	3,886
NH1	250	ZHBM1-3P-V-EFM	3 x V-Clamps, NHSN722066P0003**, incl. EFM	1SEP620021R3021	3,883
NH1, NH2	400	ZHBM2-3P-M12-EFM	3 x M12 Universal Bolts, incl. EFM	1SEP620022R3001	4,441
NH1, NH2	400	ZHBM2-3P-V-EFM	3 x V-Clamps, NHSN722066P0003**, incl. EFM	1SEP620022R3021	4,444
NH2*, NH3	630	ZHBM3-3P-M12-EFM	3 x M12 Universal Bolts, incl. EFM	1SEP620023R3001	5,013
NH2*, NH3	630	ZHBM3-3P-V-EFM	3 x V-Clamps, NHSN722066P0003**, incl. EFM	1SEP620023R3021	5,006

\* with dedicated adapter only, ZLBM3 NH2 fuse adapter – 1SEP621288R0001

\*\*see section "Quick selection" for more information



# Ordering information

## ZHBM, 3-pole with ITS2.1 monitoring unit



ZHBM00-3P-ITS2.1



ZHBM1/2/3-3P-ITS2.1

### ZHBM, 3-pole, depth 154 mm, M8, M12 Bolt or V-Clamp cable connection, single switch

ZHBM fuse switch disconnectors can be equipped with an Intelligent monitoring unit ITS2.1. The items in this table include a factory mounted ITS2.1.

Fuse size	Rated operational current $I_e$ [A]	Type	Description	Order code	Weight (Kg)
NH00	160	ZHBM00-3P-M8-ITS2.1	3 x M8 Bolts, incl. ITS2.1	1SEP622695R0001	2,82
NH00	160	ZHBM00-3P-V-ITS2.1	3 x V-Clamps, NHSN722079P0001**, incl. ITS2.1	1SEP622696R0001	2.82
NH1	250	ZHBM1-3P-M12-ITS2.1	3 x M12 Universal Bolts, incl. ITS2.1	1SEP622697R0001	4.9
NH1	250	ZHBM1-3P-V-ITS2.1	3 x V-Clamps, NHSN722066P0003**, incl. ITS2.1	1SEP622698R0001	4.9
NH1, NH2	400	ZHBM2-3P-M12-ITS2.1	3 x M12 Universal Bolts, incl. ITS2.1	1SEP622699R0001	5.46
NH1, NH2	400	ZHBM2-3P-V-ITS2.1	3 x V-Clamps, NHSN722066P0003**, incl. ITS2.1	1SEP622700R0001	5.46
NH2*, NH3	630	ZHBM3-3P-M12-ITS2.1	3 x M12 Universal Bolts, incl. ITS2.1	1SEP622701R0001	6.03
NH2*, NH3	630	ZHBM3-3P-V-ITS2.1	3 x V-Clamps, NHSN722066P0003**, incl. ITS2.1	1SEP622702R0001	6.03

\* with dedicated adapter only, ZLBM3 NH2 fuse adapter – 1SEP621288R0001

\*\*see section "Quick selection" for more information

# Ordering information

## InLine II Cu+ for high ambient temperatures, 1-pole



ZHBM2/3-T-1P



BZH1000A-T-1P

**InLine II Cu+ 1-pole version, depth 154 mm, single switch, M12 Bolt cable connection**  
Switches for usage in high ambient temperatures up 55°C without derating

Fuse size	Rated operational current I <sub>e</sub> [A]	Type	Description	Order code	Weight (Kg)
NH1, NH2	400	ZHBM2-T-1P-M12	3 x M12 Universal Bolts	1SEP620042R1000	3,9
NH1, NH2	400	ZHBM2-T-1P-M12-TK	3 x M12 Universal Bolts, incl. Terminal kit	1SEP622562R1000	5,4
NH2*, NH3	630	ZHBM3-T-1P-M12	3 x M12 Universal Bolts	1SEP620044R1000	6,4
NH2*, NH3	630	ZHBM3-T-1P-M12-TK	3 x M12 Universal Bolts, incl. Terminal kit	1SEP620043R1000	7,9
Equipped with solid links**	1000	BZH1000A-T-1P-M12	3 x M12 Universal Bolts	1SEP622203R1000	8
Equipped with solid links**	1000	BZH1000A-T-1P-M12-TK	3 x M12 Universal Bolts, incl. Terminal kit	1SEP622022R0001	14.8
NH2*, NH3	1250	ZHBM1250A-T-1P-M12-TK	6 x M12 Universal Bolts, incl. Terminal kit	1SEP622288R0001	16.4

**InLine II Cu+ 1-pole version, depth 154 mm, double switch, M12 Bolt cable connection**  
Switches for usage in high ambient temperatures up 55°C without derating

Fuse size	Rated operational current I <sub>e</sub> [A]	Type	Description	Order code	Weight (Kg)
Equipped with solid links**	1600	BZH1600A-T-1P-M12	12 x M12 Universal Bolts	1SEP622290R0001	16
Equipped with solid links**	1600	BZH1600A-T-1P-M12-TK	12 x M12 Universal Bolts, incl. Terminal kit	1SEP622024R0001	17.8
Equipped with solid links**	2000	BZH2000A-T-1P-M12	12 x M12 Universal Bolts	1SEP622294R0001	20
Equipped with solid links**	2000	BZH2000A-T-1P-M12-TK	12 x M12 Universal Bolts, incl. Terminal kit	1SEP622292R0001	22.5

\* with dedicated adapter only, ZLBM3 NH2 fuse adapter – 1SEP621288R0001

\*\* NHSN706023P9105, Solid link NH3 1000A

## Ordering information

### InLine II Cu+ for high ambient temperatures, 3-pole



ZHBM3-T-3P



BZH1600A-T-3P

#### InLine II Cu+ 3-pole versions, depth 154 mm, single switch, depth 154mm, M12 Bolt cable connection

Switches for usage in high ambient temperatures up 55°C without derating

Fuse size	Rated operational current I <sub>e</sub> [A]	Type	Description	Order code	Weight (Kg)
NH1, NH2	400	ZHBM2-T-3P-M12	3 x M12 Universal Bolts	1SEP620042R3000	3.9
NH1, NH2	400	ZHBM2-T-3P-M12-TK	3 x M12 Universal Bolts, incl. Terminal kit	1SEP622562R3000	5.4
NH2*, NH3	630	ZHBM3-T-3P-M12	3 x M12 Universal Bolts	1SEP620044R3000	6.4
NH2*, NH3	630	ZHBM3-T-3P-M12-TK	3 x M12 Universal Bolts, incl. Terminal kit	1SEP620043R3000	7.9
Equipped with solid links**	1000	BZH1000A-T-3P-M12	3 x M12 Universal Bolts	1SEP622203R3000	8
Equipped with solid links**	1000	BZH1000A-T-3P-M12-TK	3 x M12 Universal Bolts, incl. Terminal kit	1SEP622023R0001	14.8
Equipped with solid links***	1600	BZH1600A-S-T-3P-MB	2 x 3 M12 Universal Bolts, terminal connection on rear side	1SEP620133R3050	15

\* with dedicated adapter only, ZLBM3 NH2 fuse adapter – 1SEP621288R0001

\*\* NHSN706023P9105, Solid link NH3 1000A

\*\*\* BZH1600A-Solid-link

#### InLine II Cu+ 3-pole versions, depth 154 mm, double switch, M12 Bolt cable connection

Switches for usage in high ambient temperatures up 55°C without derating

Fuse size	Rated operational current I <sub>e</sub> [A]	Type	Description	Order code	Weight (Kg)
NH2*, NH3	1250	ZHBM1250A-T-3P-M12-TK	6 x M12 Universal Bolts, incl. Terminal kit	1SEP622289R0001	16.4
Equipped with solid links**	1600	BZH1600A-T-3P-M12	6 x M12 Universal Bolts	1SEP622291R0001	16
Equipped with solid links**	1600	BZH1600A-T-3P-M12-TK	6 x M12 Universal Bolts, incl. Terminal kit	1SEP622025R0001	17.8
Equipped with solid links**	2000	BZH2000A-T-3P-M12	6 x M12 Universal Bolts	1SEP622295R0001	20
Equipped with solid links**	2000	BZH2000A-T-3P-M12-TK	6 x M12 Universal Bolts, incl. Terminal kit	1SEP622293R0001	22.5

#### Accessories for InLine II Cu+

Adapter to fit 185mm switches on 210 mm busbar systems. The InLine II Cu+ adapter can be combined with each switch of the InLine II portfolio. Double switches require two adapters.

1P/3P	AD-ZLBM123-210-185	Adapter from 185 mm to 210 mm busbar	1SEP622564R0001
-------	--------------------	--------------------------------------	-----------------

# Ordering information

## BZL and BZH switch disconnectors



BZH1250A-1P



BZH1250A-3P



BZL/BZH2000A-3P

**BZL switch disconnectors, depth 121 mm**  
Cable connection via M12 Bolts, solid links are included

Fuse size	Single or double switch	Rated operational current I <sub>e</sub> [A]	Type	Description	Order code	Weight (Kg)
<b>BZL 1-pole versions, M12 Bolt cable connection</b>						
Equipped with solid links**	Single	1250	BZL1250A-1P-M12	2 x 3 M12 Universal Bolts, incl. Terminal kit 1SEP621588R0001***	1SEP620083R1000	11,2
<b>BZL 3-pole versions, M12 Bolt cable connection</b>						
Equipped with solid links**	Single	1250	BZL1250A-3P-M12	2 x 3 M12 Universal Bolts, incl. Terminal kit 1SEP621588R0001***	1SEP620083R3000	11,5
Equipped with solid links**	Double	2000	BZL2000A-3P-M12	4 x 3 M12 Universal Bolts, incl. Terminal kit 1SEP621593R0001***, incl. Double handle	1SEP620103R3000	22,8

**BZH switch disconnectors, depth 154 mm**  
Cable connection via M12 Bolts

<b>BZH 3-pole versions, M12 Bolt cable connection</b>						
Equipped with solid links**	Single	1250	BZH1250A-3P-M12	2 x 3 M12 Universal Bolts incl. Terminal kit 1SEP621588R0001***	1SEP620123R3000	11,8
Equipped with solid links**	Double	2000	BZH2000A-3P-M12	4 x 3 M12 Universal Bolts incl. Terminal kit 1SEP621593R0001***, incl. Double handle	1SEP620143R3000	23,8
<b>BZH 1-pole stainless steel versions, M12 Bolt cable connection</b>						
Equipped with solid links**	Single	1000	BZH1000A-1P-ST5-M12-CS	2 x 3 M12 Universal Bolts incl. Terminal kit 1SEP622267R0001***, cable shroud incl. 1SEP621565P0001, top plastic cover 1SEP622272P0001	1SEP622011R0001	3,75
Equipped with solid links**	Single	1600	BZH1600A-1P-ST5-M12-CS	4 x 3 M12 Universal Bolts incl. Terminal kit 1SEP622254R0001***, cable shroud incl. 1SEP622266P0001, top plastic cover 1SEP622272P0001, incl. Double handle	1SEP622012R0001	7,1

\*\* NHSN706023P9105, Solid link NH3 1000A

\*\*\*see section "Quick selection" for more information.



# Ordering information

## Bus couplers



ZLBM2/3-BC



BZH2000-1P

### Bus couplers

As interconnectors, combining two busbar systems into one.

Fuse size	Rated operational current I <sub>e</sub> [A]	Type	Description	Order code	Weight (Kg)
<b>ZLBM 3-pole bus coupler versions, depth 121 mm, single switch</b>					
NH1, NH2	400	ZLBM2-3P-BC-Right	Connection right, from left side possible by turning the base	1SEP622028R0001	3,35
NH2*, NH3	630	ZLBM3-3P-BC-Right	Connection right, from left side possible by turning the base	1SEP622030R0001	3,65
<b>ZLBM 3-pole stainless steel bus coupler versions, depth 121mm, single switch</b>					
NH2*, NH3	630	ZLBM3-3P-BC-Right-STS	Connection right, from left side possible by turning the base	1SEP620180R0001	1,7
<b>ZLBM 1-pole bus coupler versions, depth 121mm, single switch</b>					
NH1, NH2	400	ZLBM2-1P-BC-Right	Connection right, from left side possible by turning the base	1SEP622028R0002	1,2
<b>BZH 1-pole stainless steel bus coupler versions, depth 154mm, double switch</b>					
Equipped with solid links**	2000	BZH2000-1P-BC-Right-STS	Corrosion free, connection right, from left side possible by turning the base	1SEP622034R0001	11,85

\* with dedicated adapter only, ZLBM3 NH2 fuse adapter – 1SEP621288R0001

\*\* NHSN706023P9105, Solid link NH3 1000A

# Ordering information

## ZLBM, 1- and 3-pole with IP20 touch proof Z-busbar system



ZLBM00-1P-Z



ZLBM1/2/3-1P-Z



ZLBM3-3P-Z-SC



ZLBM3-3P-Z-2SC

### ZLBM, 1-pole, depth 121 mm, IP20 touch proof Z-busbar system

Equipped with Z-clamps, suitable for IP20 Z-busbar system. See pages for for Z-busbar system for more information.

Fuse size	Rated operational current I <sub>e</sub> [A]	Type	Description	Order code	Weight (Kg)
NH00	160	ZLBM00-1P-Z-M8	3 x M8 Bolts, Cable shroud included	1SEP620010R1100	2,11
NH00	160	ZLBM00-1P-Z-V	3 x V-Clamps, NHSN722079P0001**, Cable shroud included	1SEP620010R1120	2,34
NH1, NH2	400	ZLBM2-1P-Z-M12	3 x M12 Universal Bolts, Cable shroud included	1SEP620012R1100	4,5
NH2*, NH3	630	ZLBM3-1P-Z-M12	3 x M12 Universal Bolts, Cable shroud included	1SEP620013R1100	5,37
NH2*, NH3	630	ZLBM3-1P-Z-2SC	Double side connection	1SEP620013R1140	5,7

\* with dedicated adapter only, ZLBM3 NH2 fuse adapter – 1SEP621288R0001

\*\*see section "Quick selection" for more information

### ZLBM, 3-pole, depth 121 mm, IP20 touch proof Z-busbar system

Equipped with Z-clamps, suitable for IP20 Z-busbar system. See pages for for Z-busbar system for more information.

Fuse size	Rated operational current I <sub>e</sub> [A]	Type	Description	Order code	Weight (Kg)
NH00	160	ZLBM00-3P-Z-AI	3 x single AI-Clamp, Cable shroud included	1SEP620010R3160	2,32
NH00	160	ZLBM00-3P-Z-2AI	3 x double AI-Clamp, Cable shroud included	1SEP620010R3170	2,42
NH00	160	ZLBM00-3P-Z-M8	3 x M8 Bolts, Cable shroud included	1SEP620010R3100	2,21
NH00	160	ZLBM00-3P-Z-V	3 x V-Clamps, NHSN722079P0001**, Cable shroud included	1SEP620010R3120	2,44
NH1	250	ZLBM1-3P-Z-M12	3 x M12 Universal Bolts, Cable shroud included	1SEP620011R3100	4,1
NH1	250	ZLBM1-3P-Z-V	3 x V-Clamps, NHSN722066P0003**, Cable shroud included	1SEP620011R3120	4,1
NH1	250	ZLBM1-3P-Z-SC	Single side connection	1SEP620011R3130	4,53
NH1, NH2	400	ZLBM2-3P-Z-M12	3 x M12 Universal Bolts, Cable shroud included	1SEP620012R3100	4,7
NH1, NH2	400	ZLBM2-3P-Z-V	3 x V-Clamps, NHSN722066P0003**, Cable shroud included	1SEP620012R3120	4,7
NH1, NH2	400	ZLBM2-3P-Z-SC	Single side connection	1SEP620012R3130	4,63
NH1, NH2	400	ZLBM2-3P-Z-2SC	Double side connection	1SEP620012R3140	5,64
NH2*, NH3	630	ZLBM3-3P-Z-M12	3 x M12 Universal Bolts, Cable shroud included	1SEP620013R3100	5,47
NH2*, NH3	630	ZLBM3-3P-Z-V	3 x V-Clamps, NHSN722066P0003**, Cable shroud included	1SEP620013R3120	5,47
NH2*, NH3	630	ZLBM3-3P-Z-SC	Single side connection	1SEP620013R3130	4,73
NH2*, NH3	630	ZLBM3-3P-Z-2SC	Double side connection	1SEP620013R3140	5,73

\* with dedicated adapter only, ZLBM3 NH2 fuse adapter – 1SEP621288R0001

\*\*see section "Quick selection" for more information

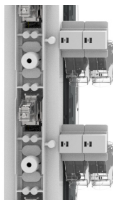

Rear view of ZLBM2-3P-Z-2SC

## Ordering information

### ZLBM, 1- and 3-pole with IP20 touch proof Z-busbar system



ZLBM800A-3P-Z-M12

#### 3-pole 800A version, double switch, M12 Bolt cable connection

Fuse size	Rated operational		Description	Order code	Weight (Kg)
	current I <sub>e</sub> [A]	Type			
NH1, NH2	800	ZLBM800A-3P-Z-M12	12 x M12 Universal Bolts, Cable shroud included	1SEP620014R3100	11,2

#### ZLBM, 3-pole, depth 121 mm, IP20 touch proof Z-clamp system, with electronic fuse monitoring (EFM)

Equipped with Z-clamps, suitable for IP20 Z-busbar system. See pages for Z-busbar system for more information. Equipped with an Electronic Fuse Monitor (EFM). The items in this table include a factory mounted EFM.

Fuse size	Rated operational		Description	Order code	Weight (Kg)
	current I <sub>e</sub> [A]	Type			
NH1	250	ZLBM1-3P-Z-V-EFM	3 x V-Clamps, NHSN722066P0003*, Cable shroud included	1SEP620011R3121	4,2
NH1, NH2	400	ZLBM2-3P-Z-M12-EFM	3 x M12 Universal Bolts, Cable shroud included	1SEP620012R3101	4,8
NH2*, NH3	630	ZLBM3-3P-Z-V-EFM	3 x V-Clamps, NHSN722066P0003*, Cable shroud included	1SEP620013R3121	5,57

\* with dedicated adapter only, ZLBM3 NH2 fuse adapter – 1SEP621288R0001

\*\*see section "Quick selection" for more information



ZLBM1/2/3-EFM

#### Side connection clamps\*

	Rm	Re	Sm	Se	Torque
New side connection clamp CIF300	50-300 mm <sup>2</sup>	50-300 mm <sup>2</sup>	50-300 mm <sup>2</sup>	50-300 mm <sup>2</sup>	50-95mm <sup>2</sup> 20Nm 120-300 mm <sup>2</sup> 35Nm

\* Can be used with Aluminium and Copper Cables

#### Al-Clamps\*

	Rm	Re	Sm	Se	Torque
1SEP619785R0001, ZLBM00 Cable clamp 2.5-95,	2,5-95mm <sup>2</sup>	2,5-95mm <sup>2</sup>	2,5-95mm <sup>2</sup>	2,5-95mm <sup>2</sup>	15Nm
1SEP619786R0001, ZLBM00 Cable clamp 2x2.5-35/95	2.5-35mm <sup>2</sup> / 2.5-95mm <sup>2</sup>	2.5-35mm <sup>2</sup> / 2.5-95mm <sup>2</sup>	2.5-35mm <sup>2</sup> / 2.5-95mm <sup>2</sup>	2.5-35mm <sup>2</sup> / 2.5-95mm <sup>2</sup>	15Nm

\* Can be used with Aluminium and Copper Cables

# Ordering information

## Z-busbar system 400 A & 630 A



PB 600-Z4

### Z-phase busbar with IP2X insulation

Separate busbars for wall mounting or as sparepart for cable distribution cabinets.  
Busbar support for wall mounting (PBSZ) is ordered separately.

Designation	Order code	Usable busbar length [mm]	Current [A]	Suitable for cabinet	No/batch	Weight [kg]
PB 350 Z4	2CGD000564A1000	261	400	NC350	1	0,2
PB 350 Z6	2CGD000564A1001	261	630	NC350	1	0,3
PB 600 Z4	2CGD000564A1003	511	400	NC600	1	0,4
PB 600 Z6	2CGD000564A1004	511	630	NC600	1	0,6
PB 850 Z6	2CGD000564A1007	761	630	NC850	1	0,9
P-RAIL MJS K00 Z AL	2CMA125694R1000	317	630	MJS 00	1	0,5
F-RAIL CPL.MJS K0 Z AL	2CMA125695R1000	517	630	MJS 0	1	0,9
F-RAIL CPL.MJS K1 Z AL	2CMA125696R1000	767	630	MJS 1	1	1,3
F-RAIL CPL.MJS K2 Z AL	2CMA125697R1000	967	630	MJS 2	1	1,7
F-RAIL CPL.MJS K3 Z AL	2CMA125698R1000	1267	630	MJS 3	1	2,1
Z-Busbar 1078-6 I	2CGD000449A1000	1055	630	-	1	0,9
Z-Busbar 553-4 I	2CGD000448A1000	530	400	-	1	0,4



PENB 600-Z4

### PEN-busbar

PEN-busbars for wall mounting or as sparepart for cable distribution cabinets.  
Busbar support for wall mounting (PENBSZ) is ordered separately.

Designation	Order code	Usable busbar length [mm]	Current [A]	Suitable for cabinet	No/batch	Weight [kg]
PENB 350 Z4	2CGD000565P1000	238	400	NC350	1	0,2
PENB 600 Z4	2CGD000956A1000	487	400	NC600	1	0,3
PB 850 Z4	2CGD000957A1000	737	400	NC850	1	0,4
MJSPEN30x400	2CMA125681R1000	334	400	MJS 00	1	0,2
MJSPEN30x600	2CMA125682R1000	534	400	MJS 0	1	0,3
MJSPEN30x850	2CMA125683R1000	784	400	MJS 1	1	0,4
MJSPEN30x1050	2CMA125684R1000	984	400	MJS 2	1	0,5
MJSPEN30x1350	2CMA125685R1000	1284	400	MJS 3	1	0,7



PB 600-Z4 close-up

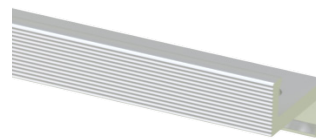

PENB 600-Z4 close-up

# Ordering information

## Z-busbar system 400 A & 630 A



### Busbar kit for wall mounting

The kit contains 3 phase busbars, 1 PEN-busbar and busbar support.

Designation	Order code	Usable busbar length [mm]	Current [A]	Suitable for cabinet	No/batch	Weight [kg]
CDC#BS 630/1250	2CMA125346R1000	1160	630	-	1	12
CDC#BS 630/900	2CMA125345R1000	810	630	-	1	8

9IBA236381

### Complete system for rebuilding cable distribution cabinet

Contains phase busbars, PEN-busbar, consoles and rear insulation.

Designation	Order code	Usable busbar length [mm]	Current [A]	Suitable for cabinet	No/batch	Weight [kg]
CDC#SZ 360-6 Busbar system	2CMA124125R1000	282	630	ND 360	-	2
CDC#SZ 610-6 Busbar system	2CMA124127R1000	534	630	ND 610	-	4
CDC#SZ 930-6 Busbar system	2CMA124329R1000	849	630	ND 930	-	6,5
CDC#SZ 1280-6 Busbar system	2CMA124331R1000	1199	630	ND 1280	-	8,5



9IBA236381 close-up



# Ordering information

## Z-busbar system 1600 A & 2500 A



Z-busbar 1600 A



Z-busbar 2500 A

### Z-busbar

1600 A & 2500 A busbars are delivered without IPX2-protection, which is ordered separately. The busbars are made of aluminium and plated with tin. Connected busbars can be of copper.

Designation	Order code	Length [mm]	Current [A]	Recommended batch size
Z-busbar 1600A 1200 mm Z Al	2CMA100041R1000	1200	1600	60
Z-busbar 1600A 1600 mm Z Al	2CMA100042R1000	1600	1600	30
Z-busbar 1600A 1800 mm Z Al	2CMA100043R1000	1800	1600	20
Z-busbar 1600A 2200 mm Z Al	2CMA100044R1000	2200	1600	20
Z-busbar 2500A 1600 mm Z Al	2CMA100037R1000	1600	2500	20
Z-busbar 2500A 1800 mm Z Al	2CMA100038R1000	1800	2500	20
Z-busbar 2500A 2200 mm Z Al	2CMA100039R1000	2200	2500	20



Rear Z-insulation



Front Z-insulation



Side insulation

### IP2X insulation

Rear- front- and side insulation is required to guarantee full IP2X-protection. Black front insulation is usually used for phase-busbars, and blue front insulation for the N-busbar. The insulation fits both 1600 A and 2500 A busbars.

Designation	Order code	Length [mm]	MOQ
Rear Z-insulation 1200 mm	2CMA100046R1000	1200	12
Rear Z-insulation 1200 mm	2CMA100047R1000	1600	12
Rear Z-insulation 1200 mm	2CMA100048R1000	1800	12
Rear Z-insulation 1200 mm	2CMA100049R1000	2200	12
Front Z-insulation Black	2CMA100051R1000	20pc x 488mm + 20pc x 378mm Total length per package 17.32 m	20 (1 package)
Front Z-insulation Blue	2CMA100053R1000	10pc x 488mm + 10pc x 378mm Total length per package 8.66 m	10 (1 package)
Side insulation	2CMA100054R1000	-	24

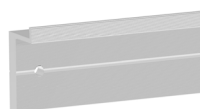

Z-busbar 1600 A close-up

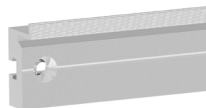

Z-busbar 2500 A close-up



Rear Z-insulation close-up

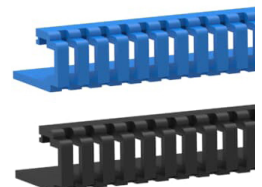

Front Z-insulation close-up

## Ordering information

### Z-busbar system 1600 A & 2500 A



ZX153

#### Busbar support

For busbars with a length of over 1 meter an extra support is recommended in the middle.

Designation	Order code	Current [A]	MOQ
ZX153 support phase busbar	2CPX044008R9999	2500	1
ZX522 support phase busbar	2CPX067909R9999	1600 A	1
ZX563 support PEN/N busbar	2CPX068735R9999	-	1



T-slot nut

#### T-slot nut

The T-slot nut is used for connecting to the back of the phase busbar and is only available for 2500 A busbars. When connecting to the back of the 1600 A busbar a hole needs to be drilled and the connecting busbar screwed.

Designation	Order code	MOQ
T-slot nut	2CMA100056R1000	12



ZX153 close-up

# Ordering information

## Accessories IP20 Z-busbars

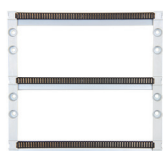

IP20 Z-busbar



9IBA184880

### IP20 Z-busbars

Z-busbars for 400/630 A. The busbar kit includes: busbar L1, L2 and L3 and two busbar holders. Degree of protection IP20. ZLBM Z-bar types are delivered with a special protection from back side in the terminal area and a standard cable shroud.

Type	Ie [A]	Width [mm]	Order code
DCN00-Z400A/445-P	400	445	1SEP201621R0001
DCN0-Z400A/578-P	400	578	1SEP201621R0002
DCN1-Z400A/774-P	400	774	1SEP201621R0004

### Accessories for IP20 Z-busbars

#### Feeding clamps

Type	Ie [A]	Cable Al/Cu mm <sup>2</sup>	Width [mm]	Order code
AKZD 95	160	6 - 95 / 2 x 6 - 50	35	1SEP731594R0001
AKKZ 300	630	50 - 300	55	1SEP731521R0001

#### Feeding clamps

Type	Order code
Insulated hexagon key, 6mm	NHSN950001P0006

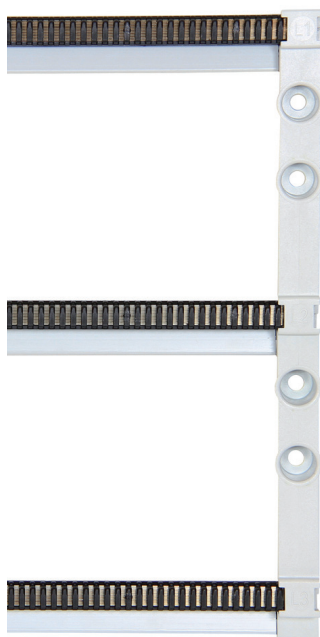

IP20 Z-busbar close-up

# Ordering information

## Accessories for ZLBM00 and ZHBM00



Cable shroud L86



Cable shroud L177



ZLBM00 Double adapter 185mm

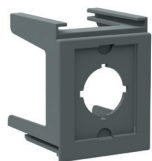

ZLBM/ZHBM 00 Label holder

### Accessories for ZLBM00-100

Type	Description	Order code	Weight (Kg)
ZLBM00-100 Side Panel Support	L-shaped plastic rails for cover panel support	1SEP621064R0001	0,05
ZLBM00-100 Label Holder	Mounted on top of the switch for labels 100 mm x 50 mm, incl. Label	1SEP621065R0001	0,05
ZLBM00-100 Single adapter for 100 to 185 mm busbar distance	100 mm to 185 mm adapter	1SEP304066R0001	0,5
ZLBM00-100 Double adapter for 100 to 185 mm busbar distance	100 mm to 185 mm adapter	1SEP304065R0001	0,7
ZLBM00-100 Auxiliary switch NO/ NC	Normally closed/ normally open	1SEP621097R0001	0,03
ZLBM00-100 Hook clamp kit	Switch via hook clamps mounted to busbars, 5 mm - 10 mm busbar thickness	1SEP621220R0001	0,1

### Accessories for ZLBM00 and ZHBM00

Type	Description	Order code	Weight (Kg)
ZLBM00 Cable shroud L86	Cable shroud with total length 86 mm	1SEP619690R0001	0,07
ZLBM00 Cable shroud L177	Cable shroud with total length 177 mm	1SEP619207R0001	0,2
ZLBM / ZHBM 00 Label holder	Mounted on top of the switch for labels 100 mm x 50 mm, incl. Label	1SEP619208R0001	0,02
ZLBM00 / ZLBM00-100 Bridge clamp	3 pcs. included, 1,5 mm <sup>2</sup> - 50 mm <sup>2</sup>	1SEP407733R0001	0,04
ZLBM00 / ZLBM00-100 Single prism clamp	3 pcs. included, 1,5 mm <sup>2</sup> - 95 mm <sup>2</sup>	1SEP407732R0005	0,1
ZLBM00 Double adapter 185 mm	ZLBM to ZHBM height alignment adapter, height increased by 32mm	1SEP619388R0001	0,11
ZLBM00 Hook clamp kit	Kit to modify M8 versions to hook clamp version mount able to flat busbars, 5 mm - 10 mm busbar thickness	1SEP619499R0001	0,3
ZLBM00 Spare way cover	Grey plastic over to close empty panel slots with a width of 50 mm, incl. Plastic rivets	1SEP304069R0001	0,1
ZLBM00 1P Operation handle kit	1 piece of 1P operation handle, also suitable for 3P variants to replace L1 and L3	1SEP621386R0001	0,1
ZLBM00 sealing facility kit	Snap on sealing facility kit for front cover, max. Ø2 mm sealing wire, 3 required for whole switch	1SEP622318R0001	0,05
Multiplug kit size 00	Multiplug mounted on top of the switch for output connection via wires with cross sec. 0,2 mm <sup>2</sup> -2,5 mm <sup>2</sup>	1SEP621080R0001	0,05
ZHBM00 CT Covers Kit	3 pcs. included, CT covers for backside	1SEP619566R0001	0,9
ZLBM00 Blind cover 50 mm	Blind cover for ZLBM00 with EFM, busbar distance 185 mm, width 50 mm	2CPX042193R9999	0,155

## Ordering information

### Ammeter and current transformers for ZLBM00 and ZHBM00



A-meter housing

#### A-meters and housing for ZLBM/ZHBM 00

The ammeter can be installed into the ammeter house. It can be clicked into position at the top of the ZLBM/ZHBM or at the bottom side if the cable terminals are upwards.

Type	Description	Order code	Weight (Kg)
ZLBM / ZHBM 00 A-meter housing 48x48 mm	Housing mounted on top of the switch or Ampere-meters 48 mmx48 mm	1SEP619209R0001	0,04
Max. A-meter QB48, 0-150-180/5A	Ampere meter with a scale up to 180 A	NHSN714003P1150	0,13



ZHBM 00 CT

#### Current transformers (CT) busbar mounting kit for ZLBM00

By using this busbar kit, CT's can be mounted at the rear side of fuse switch disconnectors ZLBM00 extending the switch depth by 32mm

Type	Description	Order code	Weight (Kg)
ZLBM CT rear side with Cu-Tube	160/5A 2,5V ACI.1, 3pcs	1SEP408149R0001	1,3

#### Current transformers (CT) for ZHBM00

CT can be fitted on the rear side of fuse switch disconnectors ZHBM00, in combination with top mounted multiplug 1SEP621080R0001 for output connection via wires

Type	Description	Order code	Weight (Kg)
ZHBM 00 CT Slide on rear side 80/1A 1,0V ACI.0,5	1pc. Per package	1SEP619863P0001	0,15
ZHBM 00 CT Slide on rear side 80/1A 1,5V ACI.1	1pc. Per package	1SEP619864P0001	0,15
ZHBM 00 CT Slide on rear side 100/1A 1,5V ACI.0,5	1pc. Per package	1SEP619865P0001	0,15
ZHBM 00 CT Slide on rear side 100/1A 2,0V ACI.1	1pc. Per package	1SEP619867P0001	0,15
ZHBM 00 CT Slide on rear side 120/1A 1,5V ACI.0,5	1pc. Per package	1SEP619868P0001	0,15
ZHBM 00 CT Slide on rear side 120/1A 2,5V ACI.1	1pc. Per package	1SEP619870P0001	0,15
ZHBM 00 CT Slide on rear side 125/1A 1,5V ACI.0,5	1pc. Per package	1SEP619871P0001	0,15
ZHBM 00 CT Slide on rear side 125/1A 2,5V ACI.1	1pc. Per package	1SEP619873P0001	0,15
ZHBM 00 CT Slide on rear side 150/1A 2,0V ACI.0,5	1pc. Per package	1SEP619874P0001	0,15
ZHBM 00 CT Slide on rear side 150/1A 2,5V ACI.1	1pc. Per package	1SEP619876P0001	0,15
ZHBM 00 CT Slide on rear side 160/1A 2,5V ACI.0,5	1pc. Per package	1SEP619877P0001	0,15
ZHBM 00 CT Slide on rear side 160/1A 2,5V ACI.1	1pc. Per package	1SEP619879P0001	0,15
ZHBM 00 CT Slide on rear side 80/5A 1,0V ACI.0,5	1pc. Per package	1SEP619880P0001	0,15
ZHBM 00 CT Slide on rear side 80/5A 1,0V ACI.1	1pc. Per package	1SEP619881P0001	0,15
ZHBM 00 CT Slide on rear side 100/5A 1,0V ACI.0,5	1pc. Per package	1SEP619882P0001	0,15



## Ordering information

### Current transformers for ZHBM00



ZHBM 00 CT

#### Current transformers (CT) for ZHBM00

CT can be fitted on the rear side of fuse switch disconnectors ZHBM00, in combination with top mounted multiplug 1SEP621080R0001 for output connection via wires

Type	Description	Order code	Weight (Kg)
ZHBM 00 CT Slide on rear side 100/5A 1,5V ACI.1	1pc. Per package	1SEP619510P0001	0,15
ZHBM 00 CT Slide on rear side 120/5A 1,5V ACI.0,5	1pc. Per package	1SEP619884P0001	0,15
ZHBM 00 CT Slide on rear side 120/5A 2,0V ACI.1	1pc. Per package	1SEP619886P0001	0,15
ZHBM 00 CT Slide on rear side 125/5A 1,5V ACI.0,5	1pc. Per package	1SEP619887P0001	0,15
ZHBM 00 CT Slide on rear side 125/5A 2,5V ACI.1	1pc. Per package	1SEP619889P0001	0,15
ZHBM 00 CT Slide on rear side 150/5A 2,0V ACI.0,5	1pc. Per package	1SEP619890P0001	0,15
ZHBM 00 CT Slide on rear side 150/5A 2,5V ACI.1	1pc. Per package	1SEP619511P0001	0,15
ZHBM 00 CT Slide on rear side 160/5A 2,0V ACI.0,5	1pc. Per package	1SEP619892P0001	0,15
ZHBM 00 CT Slide on rear side 160/5A 2,5V ACI.1	1pc. Per package	1SEP619894P0001	0,15



CT terminal

#### Current transformers (CT) for ZHBM00

CT can be fitted on the rear side of fuse switch disconnectors ZHBM00, in combination with top mounted multiplug 1SEP621080R0001 for output connection via wires

Type	Description	Order code	Weight (Kg)
CT terminal 160A/5A 5V ACI.0,5	1pc. Per package	1SEP408149R0006	0,6

# Ordering information

## Accessories for ZLBM1/2/3 and ZHBM1/2/3

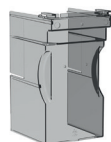

Cable shroud  
L177



Cable shroud  
L268



Cable shroud  
L390



ZLBM kit for mounting  
2 x 400/630A-1P



Cable lug kit  
double f/SWB



Cable lug kit  
2x300 mm<sup>2</sup>



ZLBM / ZHBM 123  
Label holder



Multiplug kit size 123

### Cablings and mounting accessories for ZLBM1/2/3 and ZHBM1/2/3 Additions to the switch

Type	Description	Order code	Weight (Kg)
ZLBM123 Cable shroud L86	Cable shroud with total length of 86 mm, for single switch	1SEP619211R0001	0,07
ZLBM123 Cable shroud L177	Cable shroud with total length of 177 mm, for single switch	1SEP619210R0001	0,12
ZLBM800/1250 Cable shroud L268	Cable shroud with total length of 268 mm, for double switches	1SEP619212R0001	0,37
ZLBM123 Cable shroud L390	Cable shroud with total length of 390 mm, for single switch	1SEP619213R0001	0,38
ZLBM123 Phase barrier for cable terminal	Phase barrier for additional creepage between phases L1 and L2	1SEP619682R0001	0,02
ZLBM / ZHBM 123 Label holder	Label holder top mounted	1SEP619214R0001	0,06
ZLBM / ZHBM 123 Label holder	Label holder top mounted, 250 pcs in a package	1SEP619214R0250	15
ZLBM / XLBM 123 V-Clamp kit	3 pcs. in package, Converting a M12 terminal switch into a V-Clamp version, kit includes factory mounted V-Clamps	1SEP304446R0001	0,5
V-Clamp kit 300 mm STS	3 pcs. in package, stainless steel V-Clamps, including plastic cover on top of V-Clamps	1SEP621779R0001	0,7
ZLBM123 V-Clamp kit double f/SWB (2x240)	1 pc. Cable terminal kit for M12 version switches, includes busbar extensions and factory mounted V-Clamps	1SEP621078R0001	1,37
ZLBM123 Cable lug kit double f/SWB (2x240)	ZLBM/ZHBM sizes 1/2/3 terminal extension kit for M12 versions	1SEP619276R0001	0,82
ZLBM123 Cable lug kit 2x300 mm <sup>2</sup>	ZLBM/ZHBM sizes 1/2/3 terminal extension kit for M12 versions	1SEP619277R0001	1,6
Mounting kit for ZLBM/ZHBM2/3, 3P	Double handle kit for 2 x 400/630A, 3-pole version	1SEP619216R0001	0,3
Mounting kit for ZLBM/ZHBM2/3, 1P	Double handle kit for 2 x 400/630A, 1-pole version	1SEP621008R0001	0,75
ZLBM123 Hook clamp kit	3 pcs. Hook clamps for mounting on flat busbars 5mm-10 mm thickness	1SEP619498R0001	0,3
V-Clamp kit STS for 300 mm <sup>2</sup> cable	With copper bars	1SEP621558R0001	0,6
ZLBM123 Spare part screws	M12x35 and M12 spring washers STS	1SEP621556R0001	0,25
ZLBM1 1P Operation handle kit	1 pc. included, for 1 switch are 3 pcs. of this kit required	1SEP621387R0001	0,15
ZLBM2 1P Operation handle kit	1 pc. included, for 1 switch are 3 pcs. of this kit required	1SEP621385R0001	0,15
ZLBM3 1P Operation handle kit	1 pc. included, for 1 switch are 3 pcs. of this kit required	1SEP621384R0001	0,15
ZLBM3 1P Operating handle kit, double, red (1600A)	1 pc. included, for 1 switch are 3 pcs. of this kit required	1SEP621382R0001	0,3
ZLBM3 1P Operating handle kit, single, red (1000A)	1 pc. included, for 1 switch are 3 pcs. of this kit required	1SEP621383R0001	0,15
ZLBM123 Terminal connection kit	For parallel switches V-Clamp	1SEP621072R0001	3
ZLBM123 Terminal connection kit	For parallel switches M12	1SEP621071R0001	3
ZLBM00123 Inline side cover for front panels	2 pcs. Side cover + mounting rivets included, support for front cover of enclosure	1SEP408416R0001	0,6
ZLBM123 Blindcover 100 mm	Blind cover for fuse switch disconnecter with EFM NH1-NH3, busbar system Length 185 mm, Width 100 mm	2CPX042194R9999	0,244
ZLBM3 NH2 fuse adapter	3 pcs. of adapter enabling the usage of NH2 fuses in size NH3 switches	1SEP621288R0001	0,3
Multiplug kit size 123	Multiplug mounted on top of the switch for output connection via wires with cross sec. 0,2mm <sup>2</sup> -2,5mm <sup>2</sup>	1SEP619504R0001	0,1
ZHBM123 CT Covers Kit	3 pcs. Included, CT covers for backside	1SEP619565R0001	0,2
ZLBM123 Terminal Kit for CT's	1pc. Per package	1SEP618948R0001	0,6
InLine II ITS Side protection	InLine II ITS Side protection for front panels to ensure IP20 protection	1SEP623100R0001	0,244

## Ordering information

### Current transformers for ZLBM1/2/3 and ZHBM1/2/3



ZLBM 1/2/3 CT

#### Current transformers (CT) busbar kits for ZLBM1/2/\*

By using busbar kits, CT can be mounted at the rear side of fuse switch disconnectors ZBLM123. 1SEP619504R0001

Type	Description	Order code	Weight (Kg)
ZLBM CT rear side with Cu Tube 200A/5A 3,75V ACI.1	3pc. Per package	1SEP408149R0002	1,3
ZLBMCT rear side with Cu Tube 400A/5A 5V ACI.1	3pc. Per package	1SEP408149R0003	1,3
ZLBM CT rear side with Cu Tube 600A/5A 5V ACI.1	3pc. Per package	1SEP408149R0004	1,3
ZLBM CT rear side with Cu Tube 600A/5A 5V ACI.0,5	3pc. Per package	1SEP408149R0005	1,3



ZHBM 1/2/3 CT

#### Current transformers (CT) for ZHBM1/2/3

CT can be fitted on the rear side of fuse switch disconnectors ZHBM1/2/3. 1 CT per phase.

Type	Description	Order code	Weight (Kg)
ZHBM CT Slide on rear side 250/1A 3,75V ACI.0,5	1pc. Per package	1SEP619895P0001	0,2
ZHBM CT Slide on rear side 250/1A 2,5V ACI.0,5s	1pc. Per package	1SEP619896P0001	0,2
ZHBM CT Slide on rear side 250/1A 5,0V ACI.1	1pc. Per package	1SEP619897P0001	0,2
ZHBM CT Slide on rear side 300/1A 3,75V ACI.0,5	1pc. Per package	1SEP619898P0001	0,2
ZHBM CT Slide on rear side 300/1A 3,75V ACI.0,5s	1pc. Per package	1SEP619899P0001	0,2
ZHBM CT Slide on rear side 300/1A 5,0V ACI.1	1pc. Per package	1SEP619900P0001	0,2
ZHBM CT Slide on rear side 400/1A 5,0V ACI.0,5	1pc. Per package	1SEP619901P0001	0,2
ZHBM CT Slide on rear side 400/1A 5,0V ACI.0,5s	1pc. Per package	1SEP619902P0001	0,2
ZHBM CT Slide on rear side 400/1A 5,0V ACI.1	1pc. Per package	1SEP619903P0001	0,2
ZHBM CT Slide on rear side 500/1A 5,0V ACI.0,5	1pc. Per package	1SEP619904P0001	0,2
ZHBM CT Slide on rear side 500/1A 5,0V ACI.0,5s	1pc. Per package	1SEP619905P0001	0,2
ZHBM CT Slide on rear side 500/1A 5,0V ACI.1	1pc. Per package	1SEP619906P0001	0,2
ZHBM CT Slide on rear side 600/1A 5,0V ACI.0,5	1pc. Per package	1SEP619907P0001	0,2
ZHBM CT Slide on rear side 600/1A 5,0V ACI.0,5s	1pc. Per package	1SEP619908P0001	0,2



#### Current transformers in ZHBM

The ZHBM 00/1/2/3 variants (with the additional depth +32,5mm) makes it possible to slide on one current transformer (CT) at the rear side phase.

The CT shrouds have integrated cable channels for easy cable supply up to a multi plug for external connection.

## Ordering information

### Current transformers for ZLBM1/2/3 and ZHBM1/2/3



ZHBM 1/2/3 CT



ZHBM 1/2/3 CT Covers kit

#### Current transformers (CT) for ZHBM 1/2/3

CT can be fitted on the rear side of fuse switch disconnectors ZHBM1/2/3. 1 CT per phase.

Type	Description	Order code	Weight (Kg)
ZHBM CT Slide on rear side 600/1A 5,0V ACI.1	1pc. Per package	1SEP619909P0001	0,2
ZHBM CT Slide on rear side 250/5A 3,75V ACI.0,5	1pc. Per package	1SEP619910P0001	0,2
ZHBM CT Slide on rear side 250/5A 2,5V ACI.0,5s	1pc. Per package	1SEP619911P0001	0,2
ZHBM CT Slide on rear side 250/5A 3,75V ACI.1	1pc. Per package	1SEP619512P0001	0,2
ZHBM CT Slide on rear side 300/5A 3,75V ACI.0,5	1pc. Per package	1SEP619912P0001	0,2
ZHBM CT Slide on rear side 300/5A 3,75V ACI.0,5s	1pc. Per package	1SEP619913P0001	0,2
ZHBM CT Slide on rear side 300/5A 5,0V ACI.1	1pc. Per package	1SEP619914P0001	0,2
ZHBM CT Slide on rear side 400/5A 5,0V ACI.0,5	1pc. Per package	1SEP619915P0001	0,2
ZHBM CT Slide on rear side 400/5A 5,0V ACI.0,5s	1pc. Per package	1SEP619916P0001	0,2
ZHBM CT Slide on rear side 400/5A 5V ACI.1	1pc. Per package	1SEP619513P0001	0,2
ZHBM CT Slide on rear side 500/5A 5,0V ACI.0,5	1pc. Per package	1SEP619917P0001	0,2
ZHBM CT Slide on rear side 500/5A 5,0V ACI.0,5s	1pc. Per package	1SEP619918P0001	0,2
ZHBM CT Slide on rear side 500/5A 5,0V ACI.1	1pc. Per package	1SEP619919P0001	0,2
ZHBM CT Slide on rear side 600/5A 5,0V ACI.0,5	1pc. Per package	1SEP619920P0001	0,2
ZHBM CT Slide on rear side 600/5A 5,0V ACI.0,5s	1pc. Per package	1SEP619921P0001	0,2
ZHBM CT Slide on rear side 600/5A 5V ACI.1	1pc. Per package	1SEP619514P0001	0,2

#### Current transformers (CT) for ZHBM1/2/3

Type	Description	Order code	Weight (Kg)
ZLBM CT Terminal 200/5A 3,75V ACI.1	1pc. Per package	1SEP619506R0001	0,6
ZLBM CT terminal 400/5A 5V ACI.1	1pc. Per package	1SEP619516R0001	0,6
ZLBM CT terminal 600/5A 5V ACI.1	1pc. Per package	1SEP619517R0001	0,6
ZLBM CT terminal 600/5A 5V ACI.0,5	1pc. Per package	1SEP619519R0001	0,6



CT busbar kits for ZLBM 00 and ZLBM1/2/3

# Ordering information

## Ammeter for ZLBM123 and ZHBM123



A-meter housing

### A-Meter and housing for ZLBM1/2/3 and ZHBM1/2/3

The ammeter can be installed into the ammeter house. It can be clicked into position at the top of the ZLBM/ZHBM or at the bottom side if the cable terminals are upwards.

Type	Description	Order code	Weight (Kg)
ZLBM / ZHBM 123 A-meter housing for A-meter 72x72 mm	1pc. Per package	1SEP619215R0001	0,13
Max A-meter QB72, 0-150-180/5A	1pc. Per package	NHSN714004P2206	0,2
Max A-meter QB72, 0-200-300/5A	1pc. Per package	NHSN714004P2208	0,2
Max A-meter QB72, 0-400-480/5A	1pc. Per package	NHSN714004P2210	0,2
Max A-meter QB72, 0-600-720/5A	1pc. Per package	NHSN714004P2212	0,2



Huckepack

### Huckepack for ZLBM1/2/3 and ZHBM1/2/3

A plug in Huckepack for temporary additional output can be plugged through the front window into the incoming fuse contact in the apparatus. The huckepack is prepared for a NH 00 fuse link inside, and is equipped with its own cable terminal at the bottom side.

Type	Description	Order code	Weight (Kg)
ZLBM123 Huckepack		NHSN722068P0002	0,3



Plug in A-meter and CT at NH2 fuse link

### Plug-in ammeters and CT for ZLBM1/2/3 and ZHBM1/2/3

Plug in ammeter through the front window by using a special NH2 Fuse link together with a slide in CT.

Type	Description	Order code	Weight (Kg)
Plug in CT for front cover inst. A-meter 200/5A 3,5V ACI.3		NHSN718050P2525	0,1
Plug in CT for front cover inst. A-meter 400/5A 5V ACI.3		NHSN718050P2540	0,1



Auxiliary switch

### Auxiliary switches for ZLBM1/2/3 and ZHBM1/2/3

In the ZLBM / ZHBM the auxiliary switches 1 NO or 1 NC can be clicked into position at the side of the apparatus. The body of the apparatus have integrated cable channels for easy connection down or up to a possible multi plug for external connection. ZLBM00 and ZHBM00: 1 Aux. Switch per phase. ZLBM1/2/3 and ZHBM1/2/3: 2 Aux. Switches per phase.

Type	Description	Order code	Weight (Kg)
ZLBM Auxiliary switch NC	1pc. Per package	1SEP619554R0001	0,02
ZLBM Auxiliary switch NO	1pc. Per package	1SEP619555R0001	0,02



Huckepack



Mounting position of the auxiliary switch

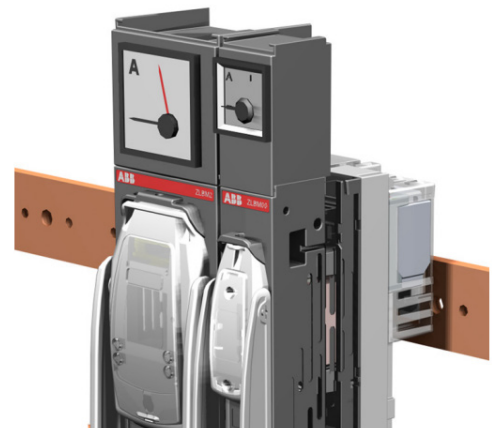









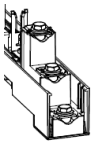





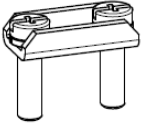









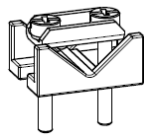

Ammeter and housing

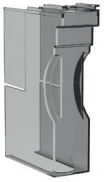











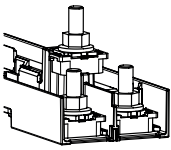
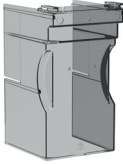
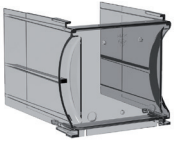

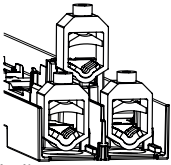

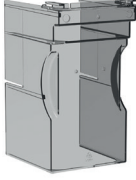
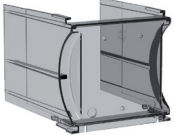



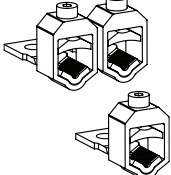

# Quick selection of cable terminations and shrouds

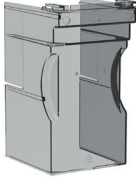
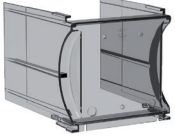
## ZLBM00/00-100 and ZHBM00

Type of clamp/bolt	Conductor cross section min-max		Torque [Nm]	Type of cable shroud (can be used for both, top and bottom)		
	Rm/Sm [mm <sup>2</sup> ]	Re/Se [mm <sup>2</sup> ]		1SEP619690R0001	1SEP619207R0001	
M8 Bolts (Standard)	1.5-95	1.5-95	10	1SEP619690R0001	1SEP619207R0001	
						
Integrated V-Clamps	10-95	10-95	10	1SEP619690R0001	1SEP619207R0001	
						
Including NHSN722079P0001						
Bridge Clamp 1SEP407733R0001		Al/Cu	3,5	1SEP619690R0001	1SEP619207R0001	
	Rm: 1,5-16		Re: 1,5-16			
	25-50		25-50			
	Sm: 1,5-16		Se: 1,5-16			
	25-50		25-50			
Single Prism Clamp 1SEP407732R0005		Al/Cu	3,5	1SEP619690R0001	1SEP619207R0001	
	Rm: 1,5-16		Re: 1,5-16			
	25-95		25-95			
	Sm: 1,5-16		Se: 1,5-16			
	25-95		25-95			

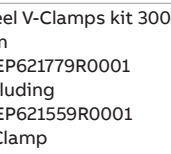

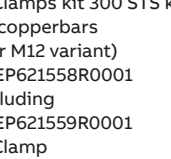





# Quick selection of cable terminations and shrouds

## ZLBM1/2/3 and ZHBM1/2/3

Type of clamp/bolt	Conductor cross section min-max		Torque [Nm]	Type of cable shroud (can be used for both, top and bottom)	
	Rm/Sm [mm <sup>2</sup> ]	Re/Se [mm <sup>2</sup> ]			
Universal Bolts M12x40 (Standard)	Max 240	Max 240	25	1SEP619210R0001	1SEP619211R0001
					
Integrated V-Clamps	Rm: 25-50 	Re: 25-50 	25	1SEP619210R0001	1SEP619211R0001
	70-185 	70-240 			
Including NHSN722066P0003	Sm: 35-50 	Se: 35-70 			
	70-240 	95-300 			
V-Clamps kit 1SEP304446R0001 (for M12 variant)	Rm: 25-50 	Re: 25-50 	25	1SEP619210R0001	1SEP619211R0001
	70-185 	70-240 			
Including NHSN722066P0003	Sm: 35-50 	Se: 35-70 			
	70-240 	95-300 			
Steel V-Clamps kit 300 mm 1SEP621779R0001 Including 1SEP621559R0001 V-Clamp	Rm: 120-185	Re: 120-240	30	1SEP619690R0001	1SEP619207R0001
	Sm: 120-240	Se: 120-300			
V-Clamps kit 300 STS kit w/copperbars (for M12 variant) 1SEP621558R0001 Including 1SEP621559R0001 V-Clamp	Rm: 120-185	Re: 120-240	30	1SEP619690R0001	1SEP619207R0001
	Sm: 120-240	Se: 120-300			

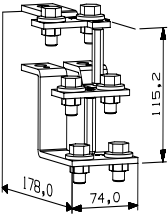
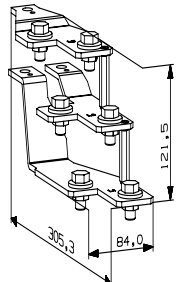

# Quick selection of cable terminations and shrouds

## ZLBM1/2/3 and ZHBM1/2/3

Type of clamp/bolt	Conductor cross section min-max		Torque [Nm]	Type of cable shroud (can be used for both, top and bottom)	
	Rm/Sm [mm <sup>2</sup> ]	Re/Se [mm <sup>2</sup> ]			
Double V-Clamp kit for switchboards 1SEP621078R0001 (for M12 variant)	Rm: 2 x 25-50		Re: 2 x 25-50		1SEP619210R0001 1SEP619211R0001
	2 x 70-185		2 x 70-240		
	Sm: 2 x 35-50		Se: 2 x 35-70		1SEP619213R0001
	2 x 70-240		2 x 95-300		
Including NHSN722066P0003					
1SEP619276R0001 Double cable lug kit f/ SWB	2 x Max 240	2 x Max 240	25	1SEP619210R0001 1SEP619211R0001	1SEP619213R0001
					
1SEP619277R0001 Double cable lug kit	2 x Max 300	2 x Max 300	25	1SEP619210R0001 1SEP619211R0001	1SEP619213R0001
					

# Quick selection of cable terminations and shrouds

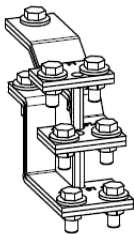
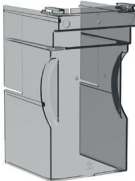
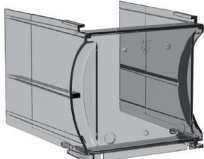
## BZL and BZH

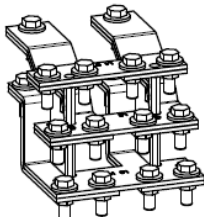
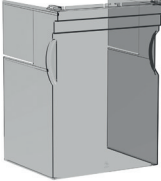
Type of clamp/bolt	Conductor cross section min-max		Torque [Nm]	Type of cable shroud (can be used for both, top and bottom)	
	Rm/Sm [mm <sup>2</sup> ]	Re/Se [mm <sup>2</sup> ]			
Lug cable connection 1SEP621588R0001	2x300	2x300	35	1SEP619210R0001	1SEP619211R0001
					
				1SEP619213R0001	
					
Lug cable connection for double switches 1SEP621593R0001	4x300	4x300	35	1SEP619212R0001	
					



—  
03

## Dimensional drawings



---

## Dimensional drawings

### Dimension drawings

ZLBM00	61
ZLBM1/2/3	63
ZLBM800/1250	66
ZLBM1250A	67
ZLBM910A	68
BZL1250A	70
BZH1250A	71
BZL2000A	72
ZHBM00	73
ZHBM1/2/3	74
Electronic Fuse Monitoring (EFM)	75
ZHBM with ITS2.1 monitoring unit	76
Bus Couplers	77
BZH1600A-S-T-3P-MB	79
Cable shrouds	80
Ammeter house	81
Label holders	82



# Dimension drawings ZLBM00

ZLBM00-3P

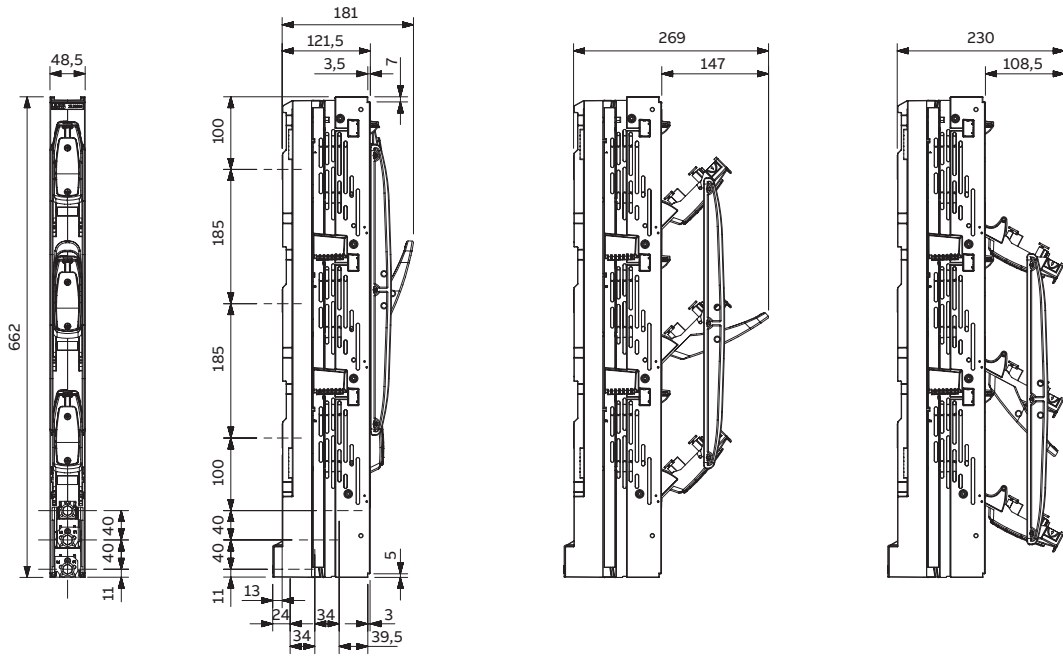

ZLBM00-1P-Z-M8

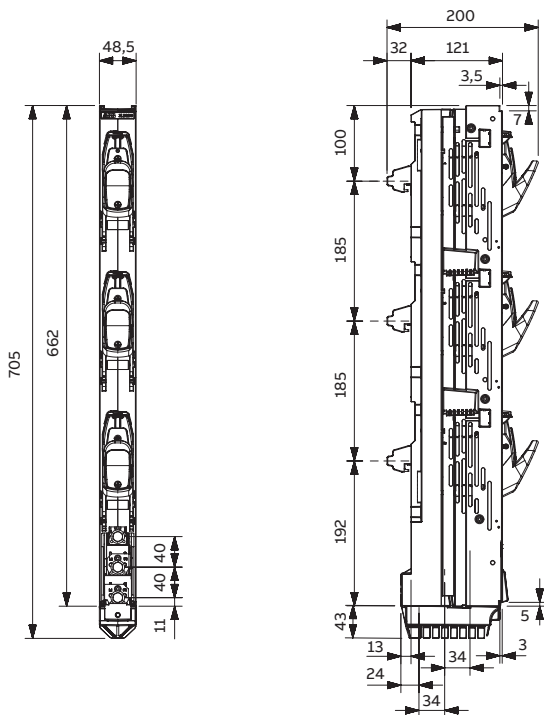

ZLBM00-3P-Z-M8

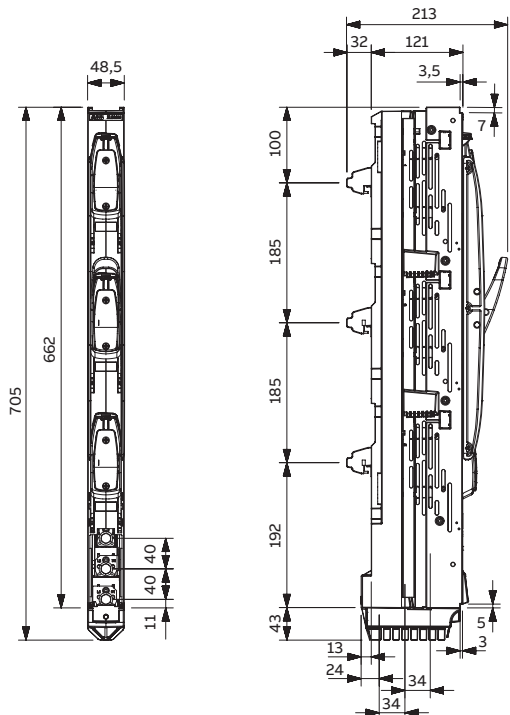

# Dimension drawings

## ZLBM1/2/3

ZLBM1/2/3 -1P

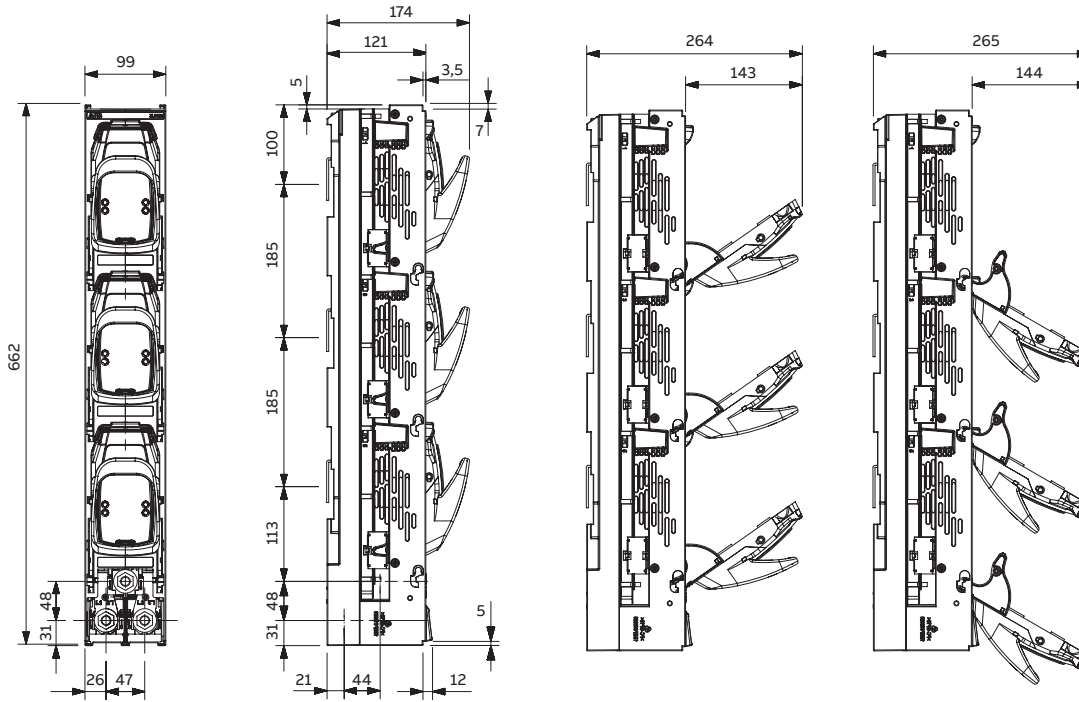

# Dimension drawings

## ZLBM1/2/3

### ZLBM1/2/3-3P

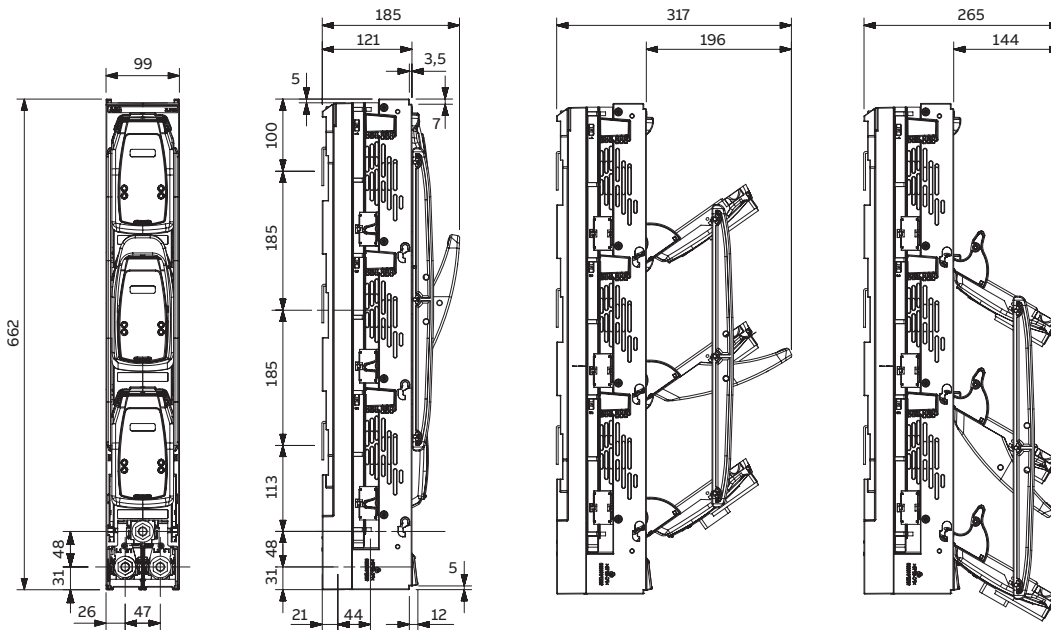

### ZLBM2-1P-Z-M12

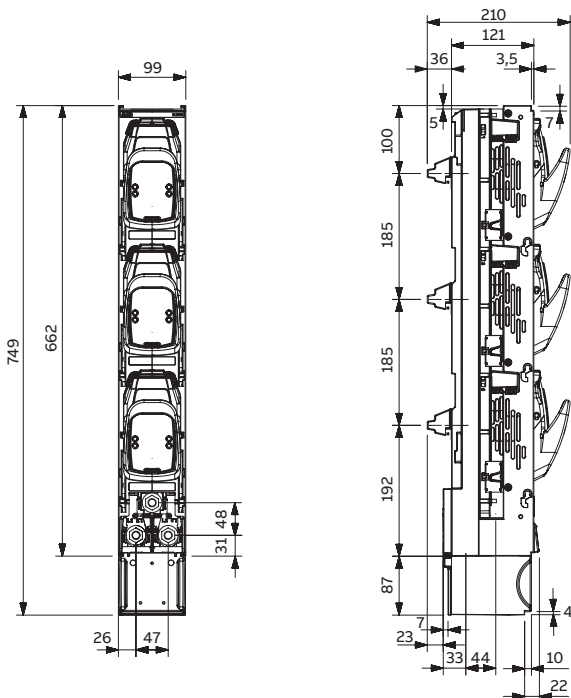





# Dimension drawings

## ZLBM800/1250

ZLBM800/1250-1P

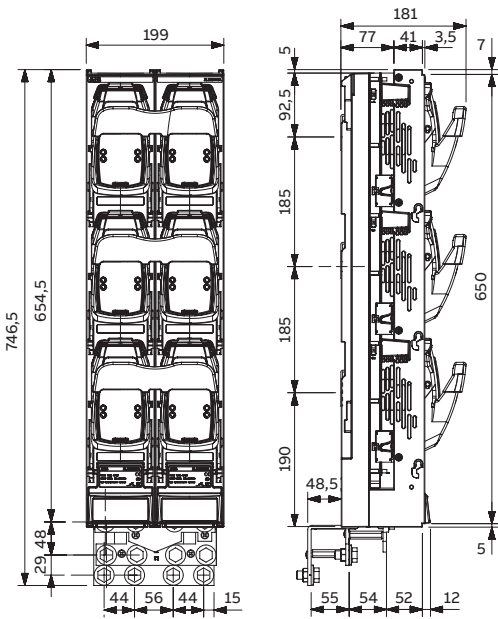

ZLBM800/1250-3P

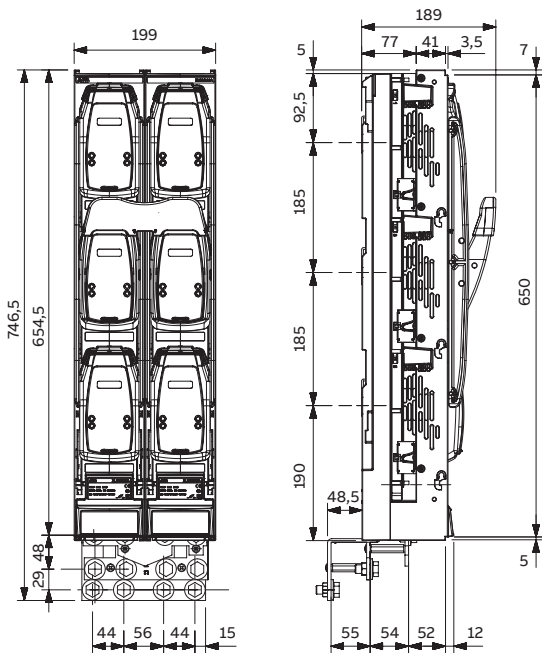

ZLBM800A-3P-Z-M12

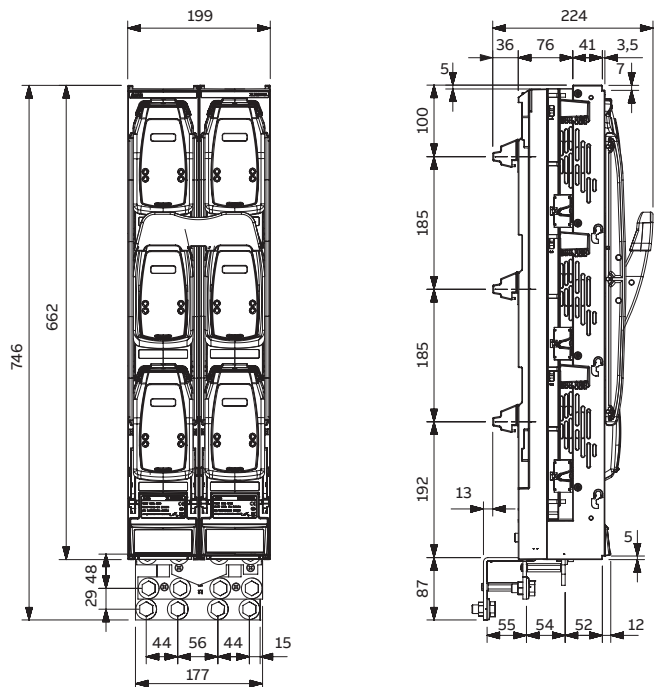

# Dimension drawings

## ZLBM1250A

ZLBM1250A-3P-Z-M12

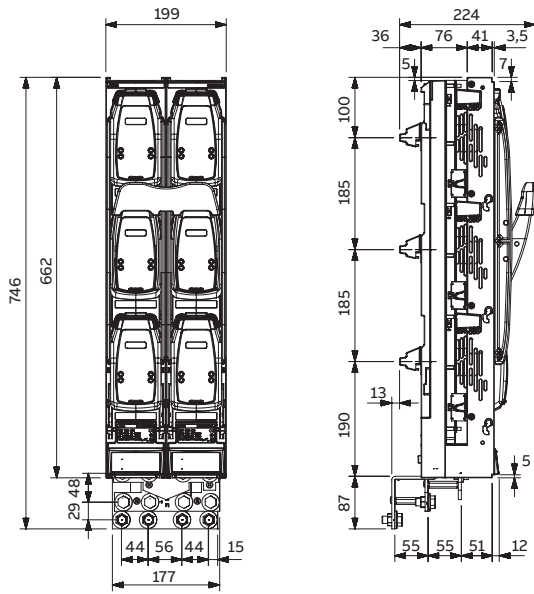

# Dimension drawings

## ZLBM910A

### ZLBM910A-1P-M12

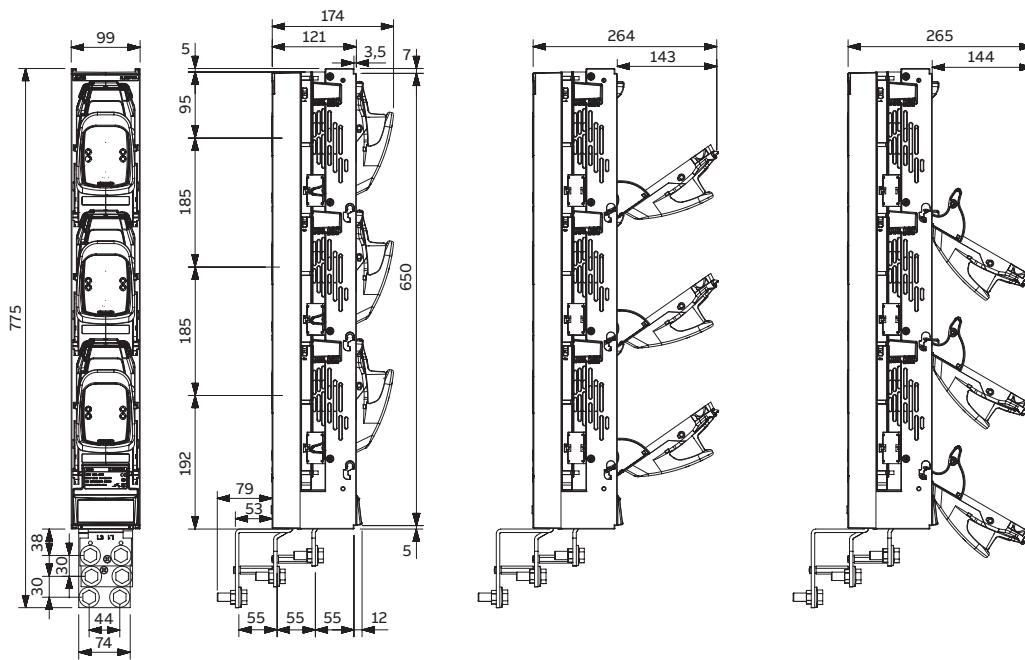

# Dimension drawings

## ZLBM910A

ZLBM910A-3P-M12-MB

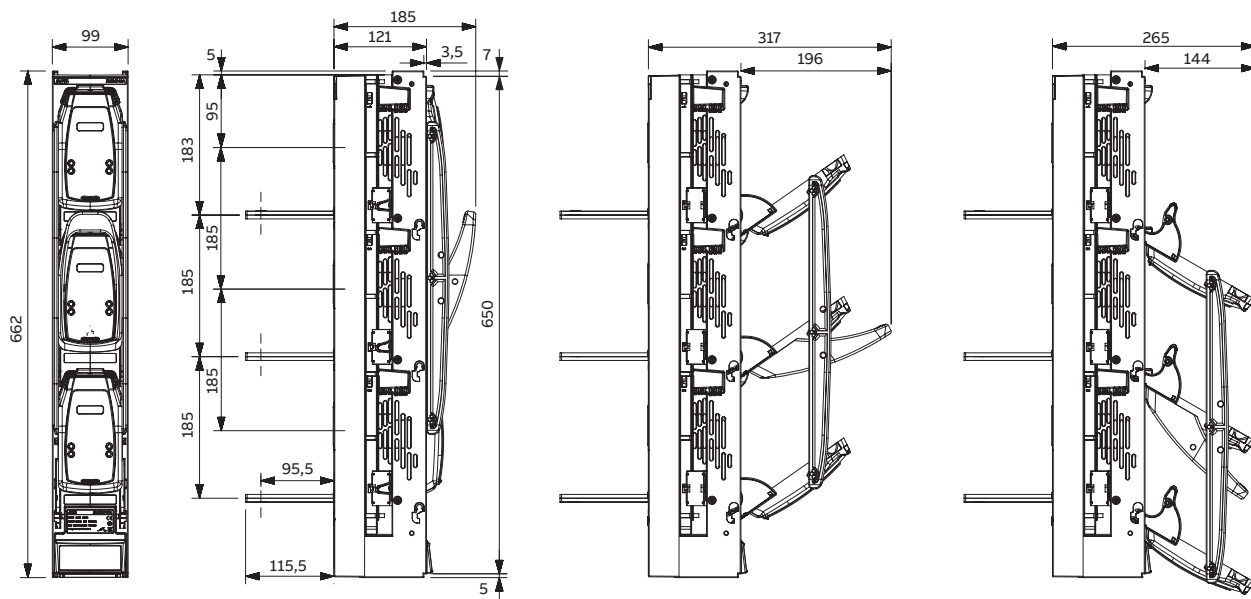

# Dimension drawings

## BZL1250A

**BZL1250A-1P-M12**

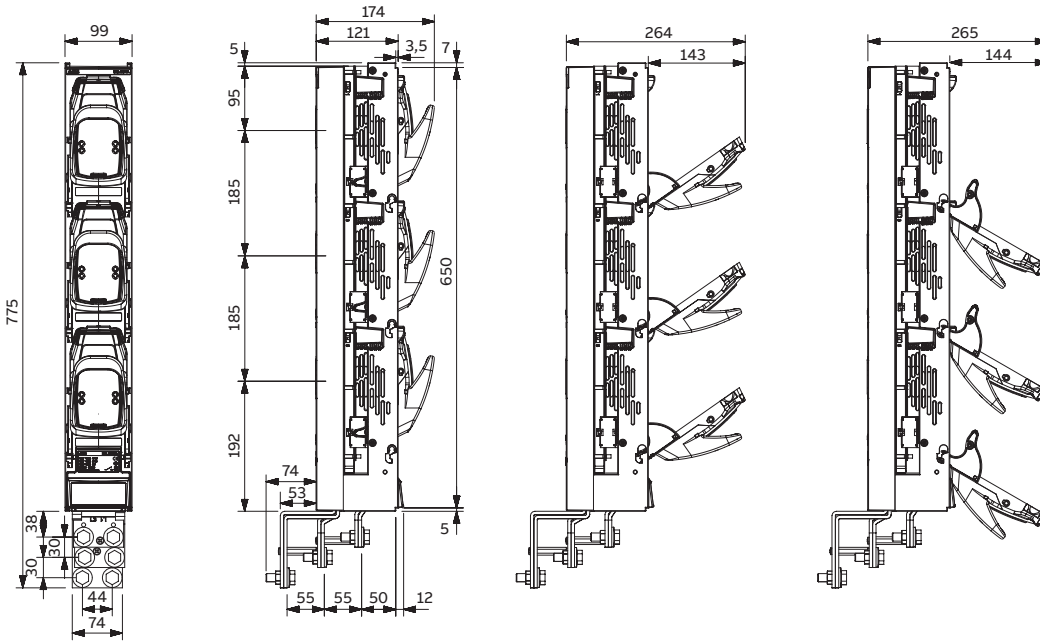

**BZL1250A-3P-M12**

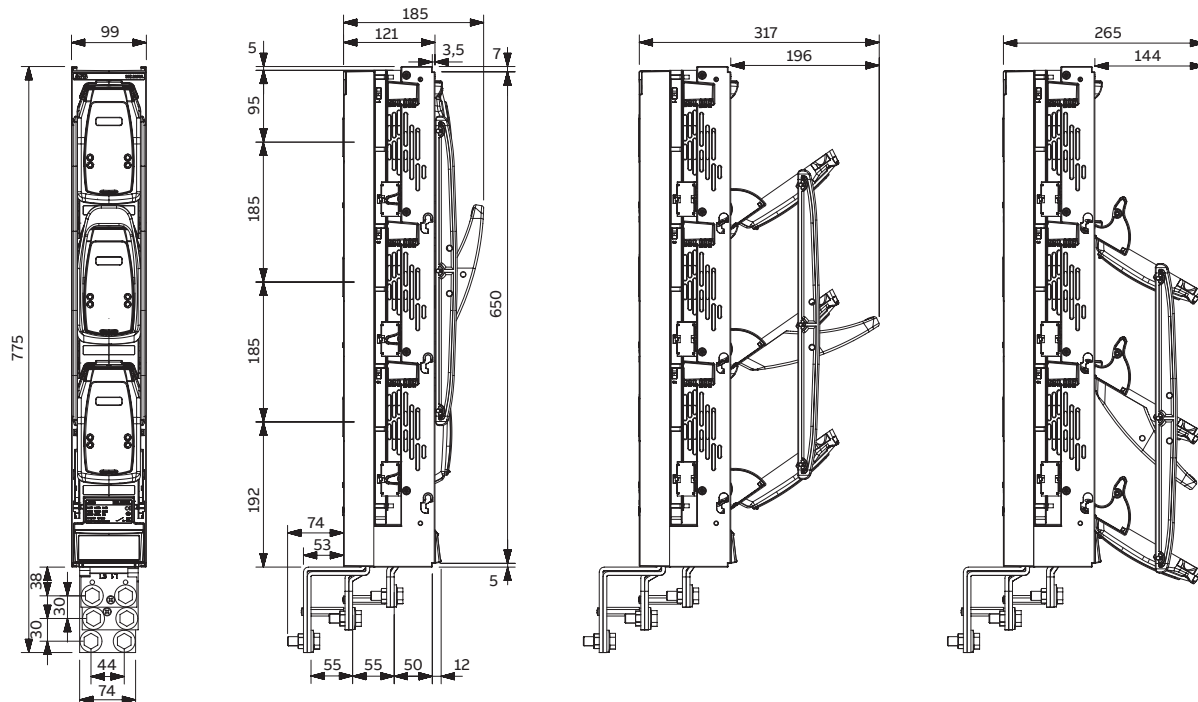

# Dimension drawings

## BZH1250A

BZH1250A-3P-M12

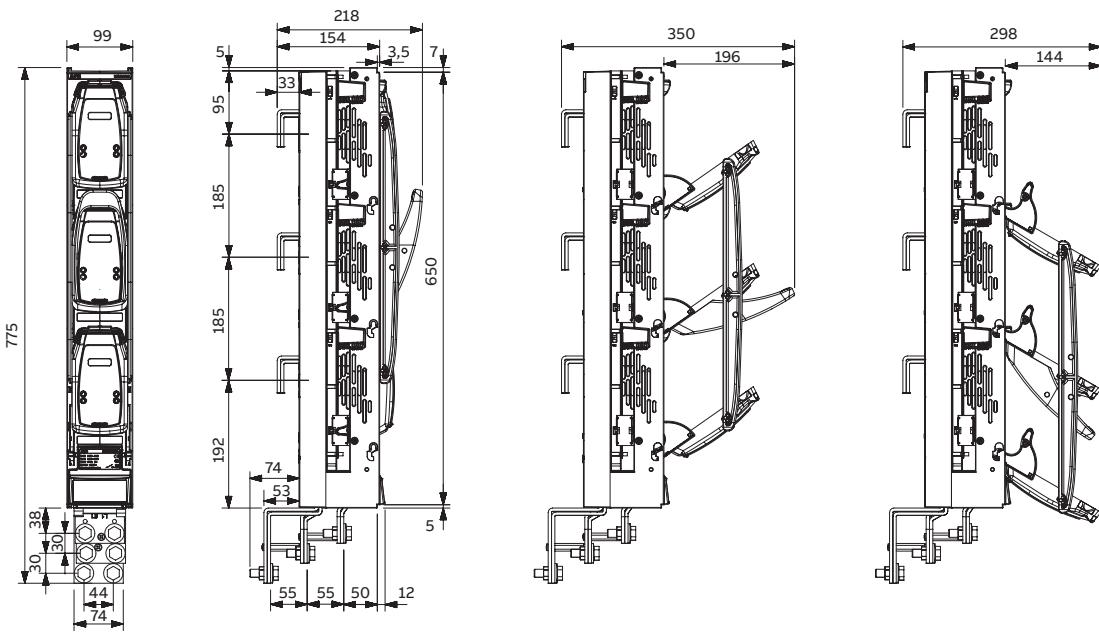



# Dimension drawings

## BZL2000A

BZL2000A-3P-M12

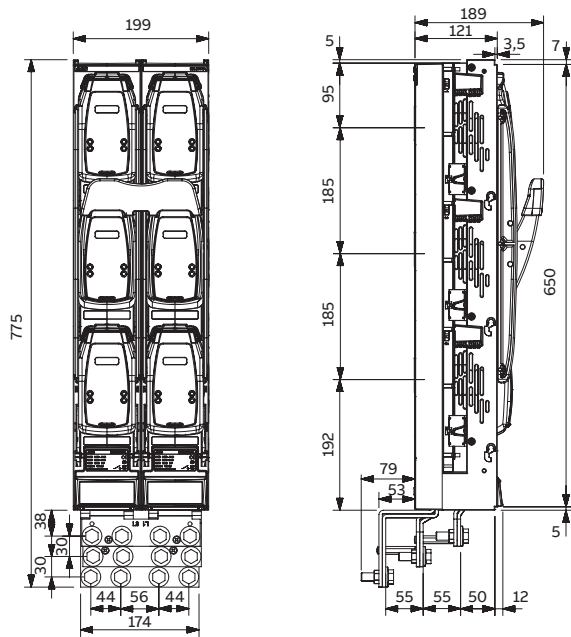

# Dimension drawings

## ZHBM00

ZHBM00-1P

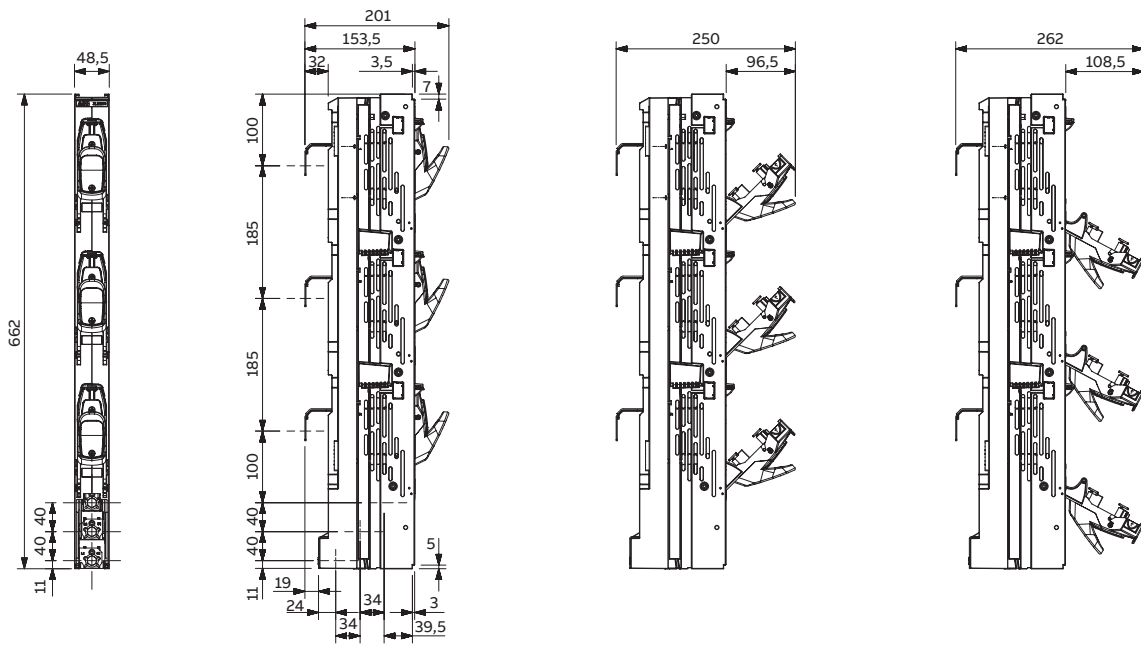

ZHBM00-3P

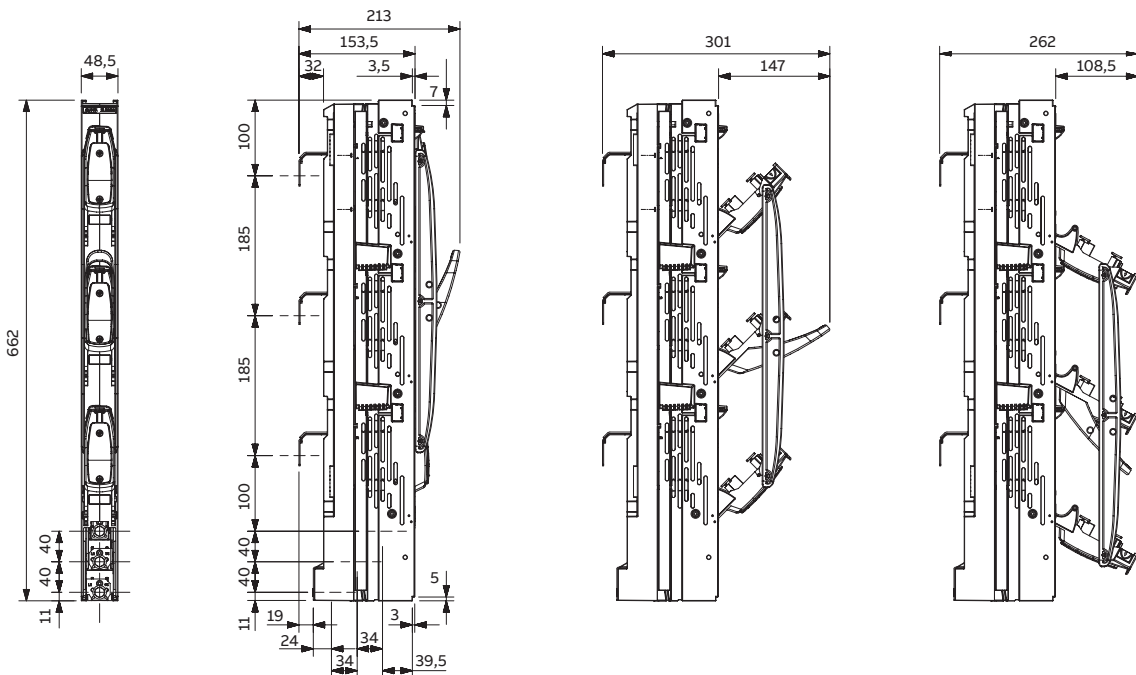

# Dimension drawings

## ZHBM1/2/3

### ZHBM1/2/3-1P

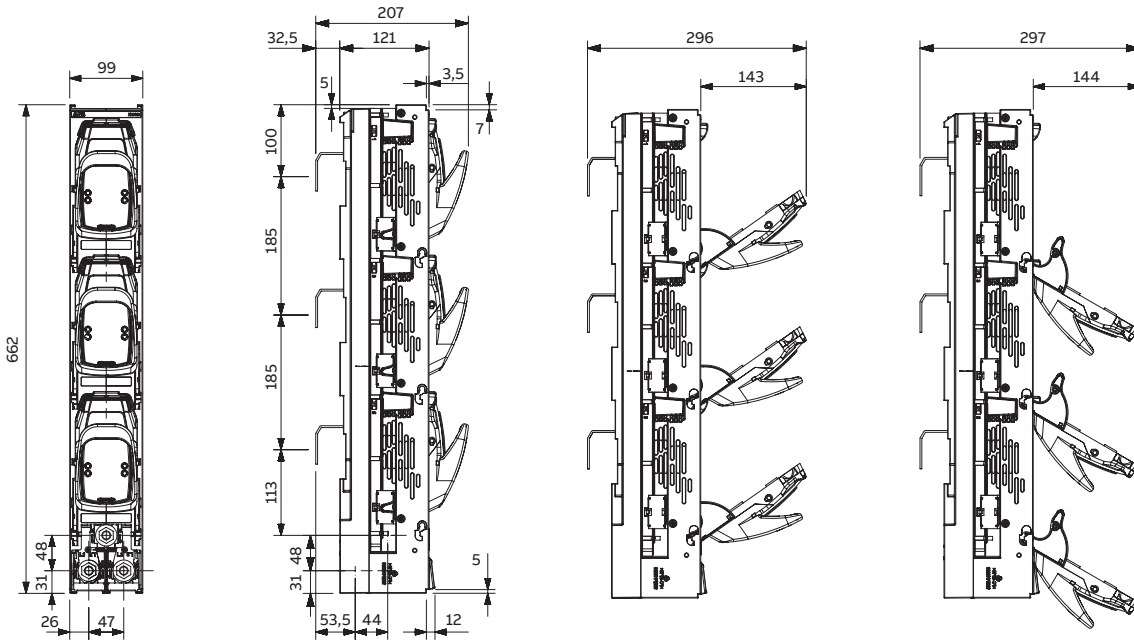

### ZHBM1/2/3-3P

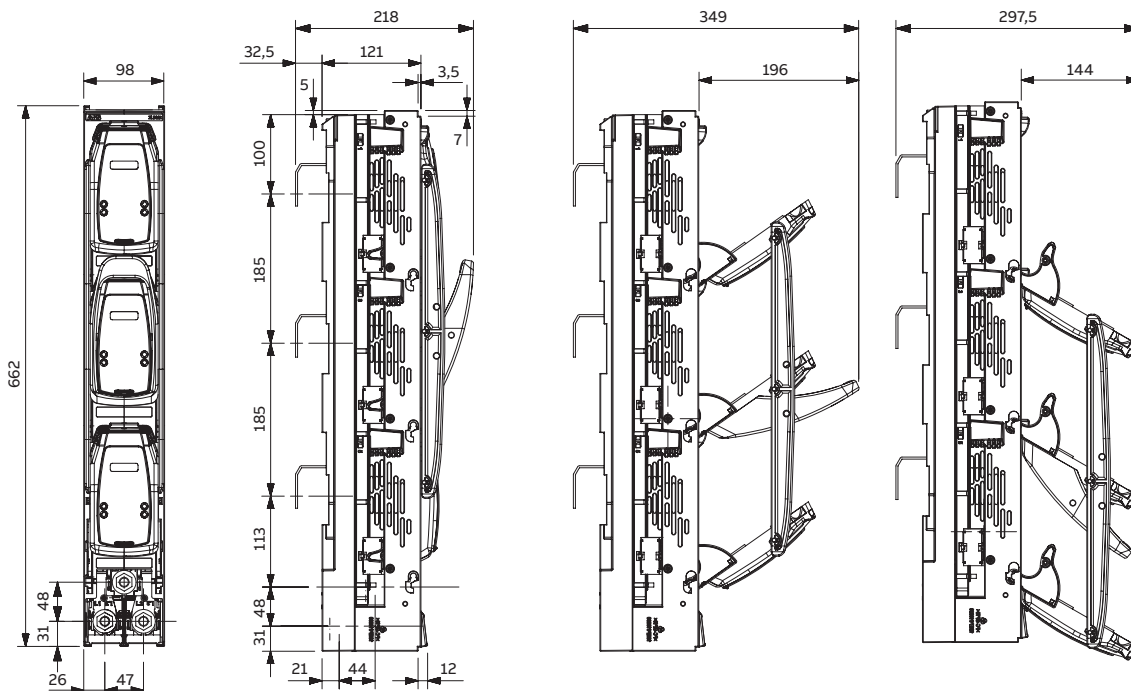

# Dimension drawings

## Electronic Fuse Monitoring (EFM)

ZLBM00-EFM

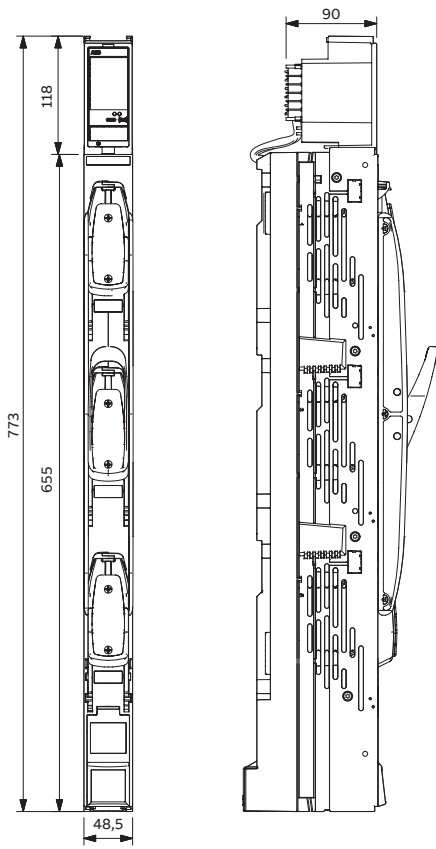

ZLBM1/2/3-EFM

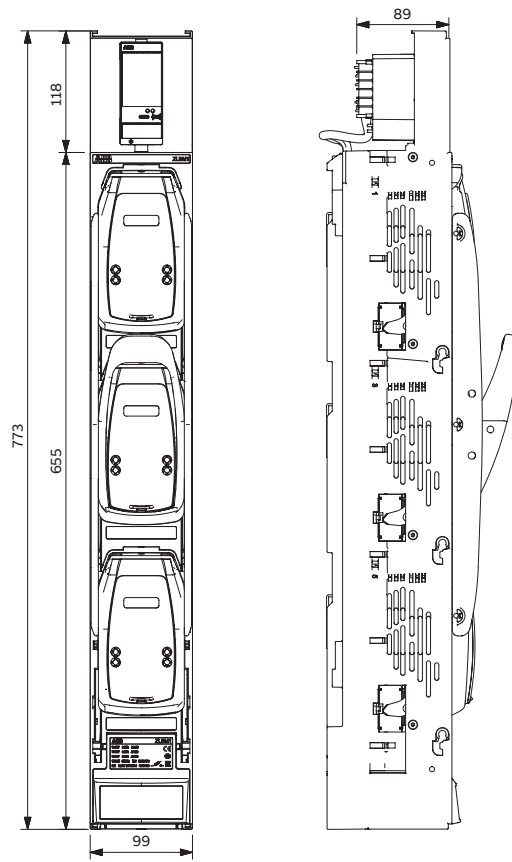

## Dimension drawings

### ZHBM with ITS2.1 monitoring unit

ZHBM00-3P -ITS2.1

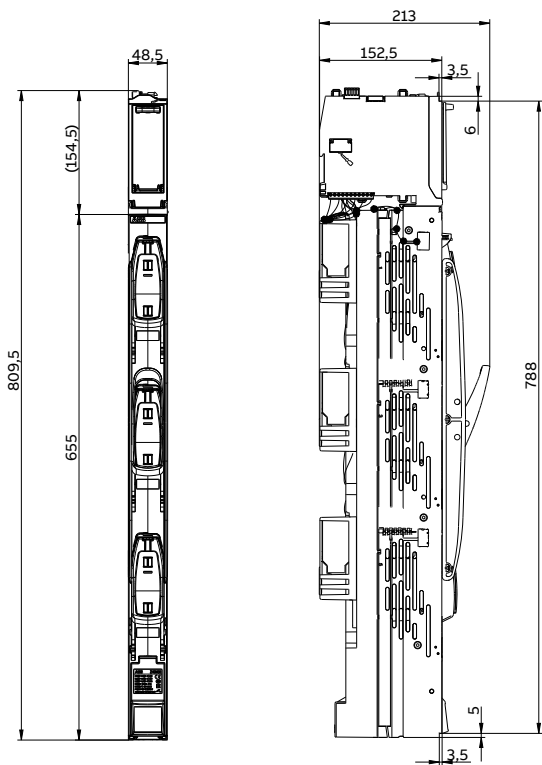

ZHBM1/2/3-3P -ITS2.1

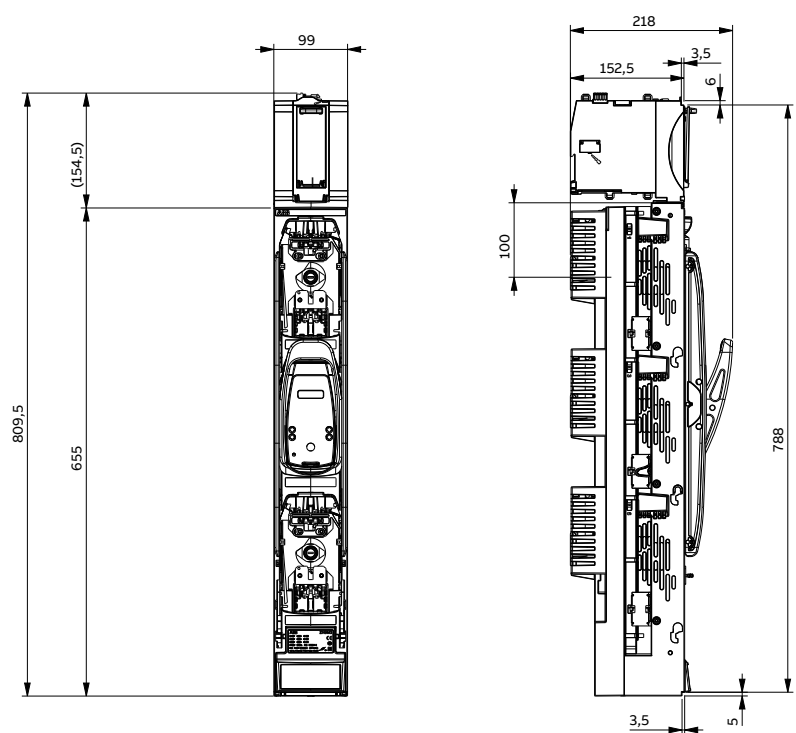

# Dimension drawings

## Bus Couplers

**BZH2000A-1P-BC**

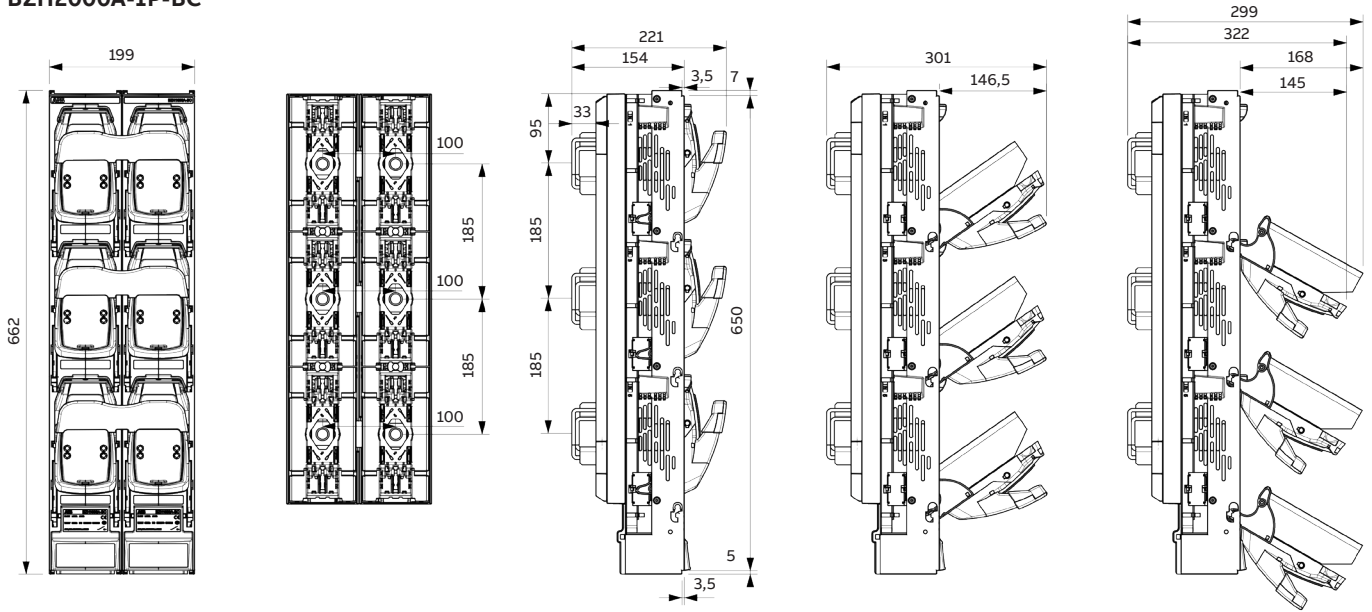



# Dimension drawings

## Bus Couplers

### ZLBM2-BC, ZLBM3-BC

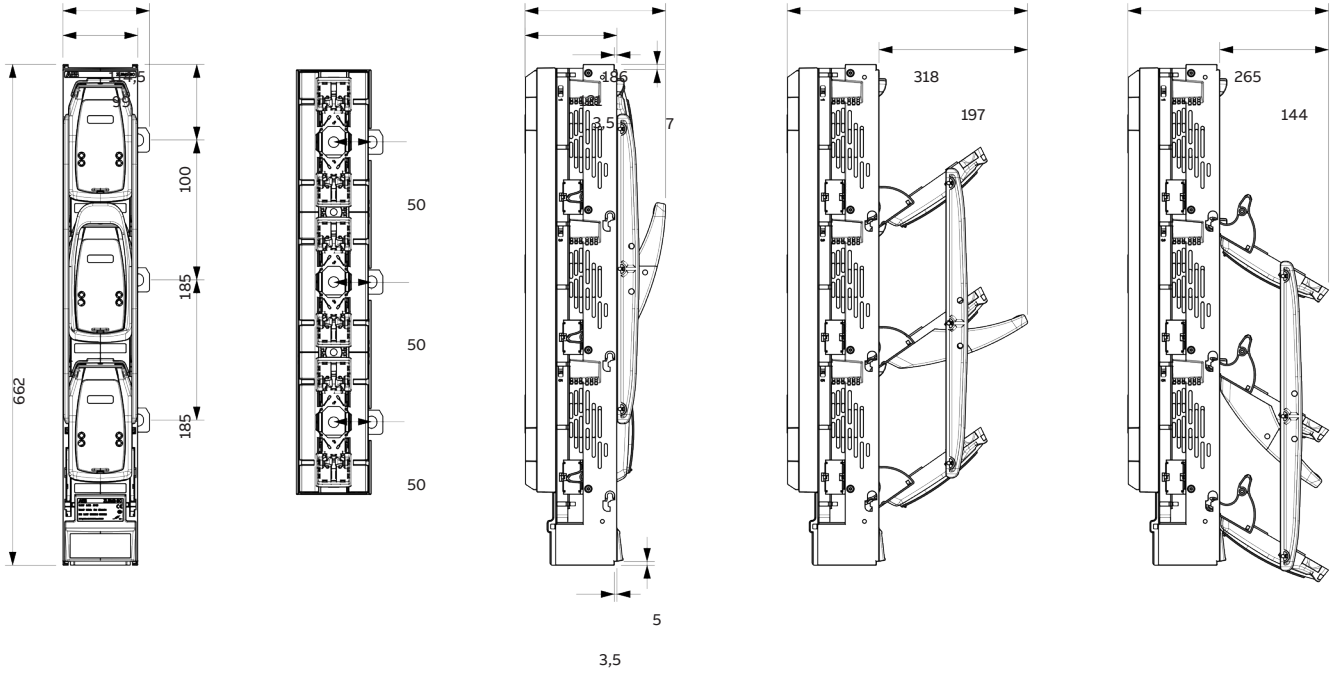

# Dimension drawings

## BZH1600A-S-T-3P-MB

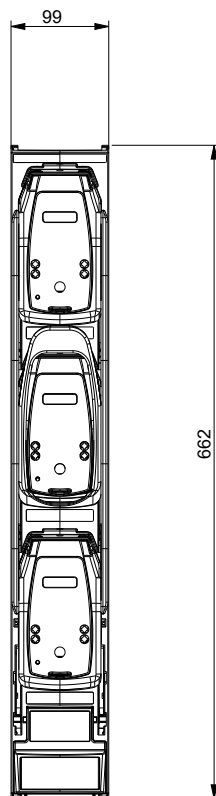
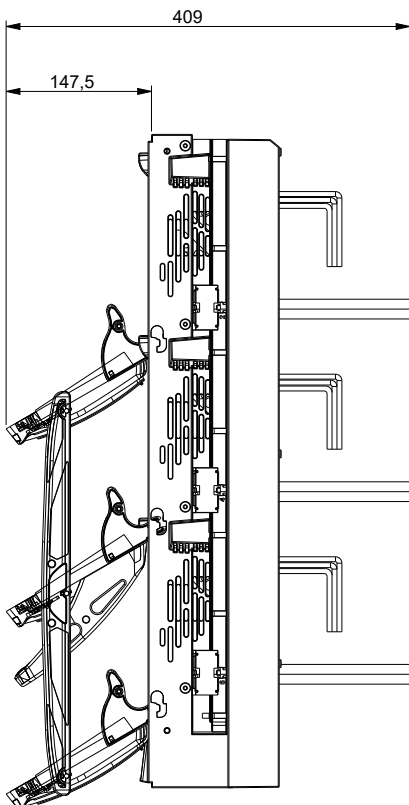
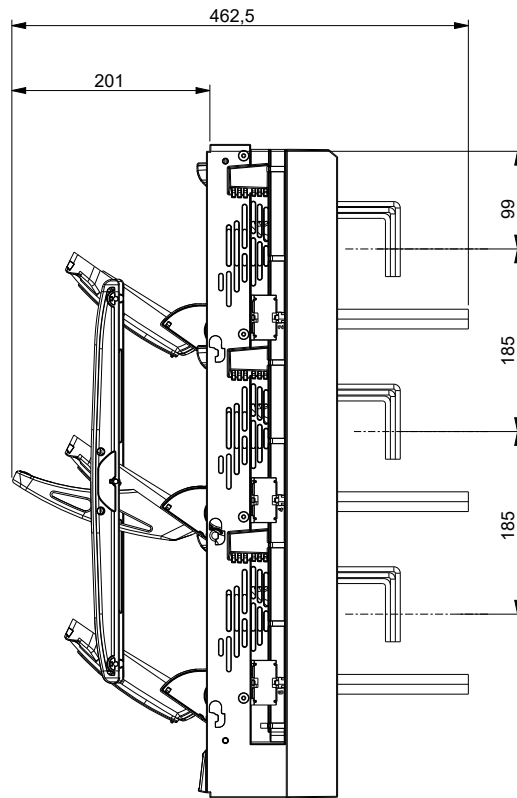
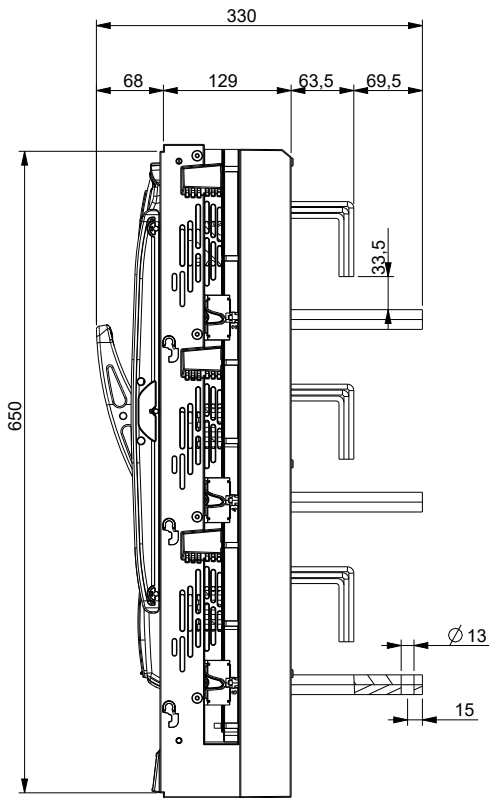

# Dimension drawings

## Cable shrouds

### ZLBM00

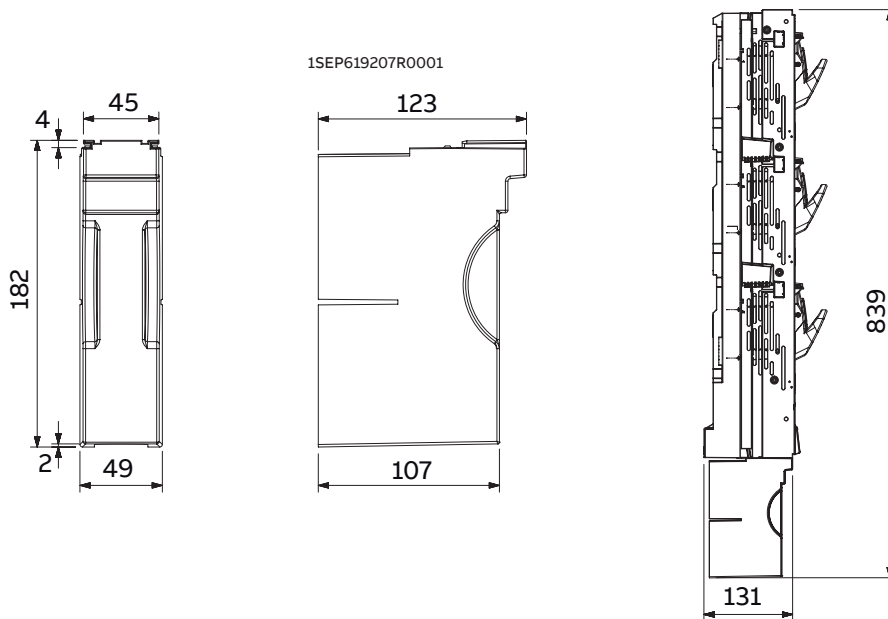

### ZLBM1/2/3

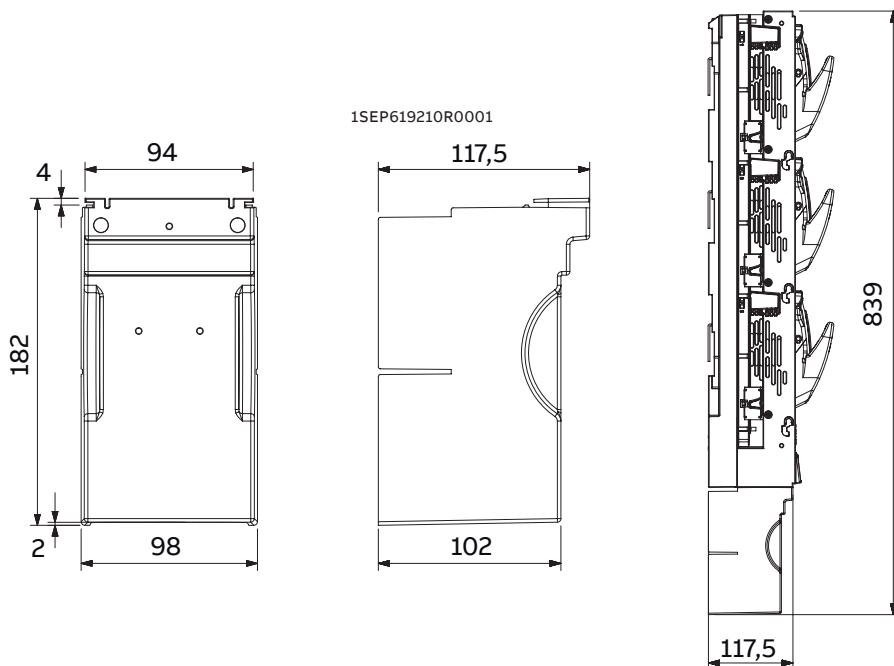

**Dimension drawings**  
Ammeter house

I  
ZLBM00

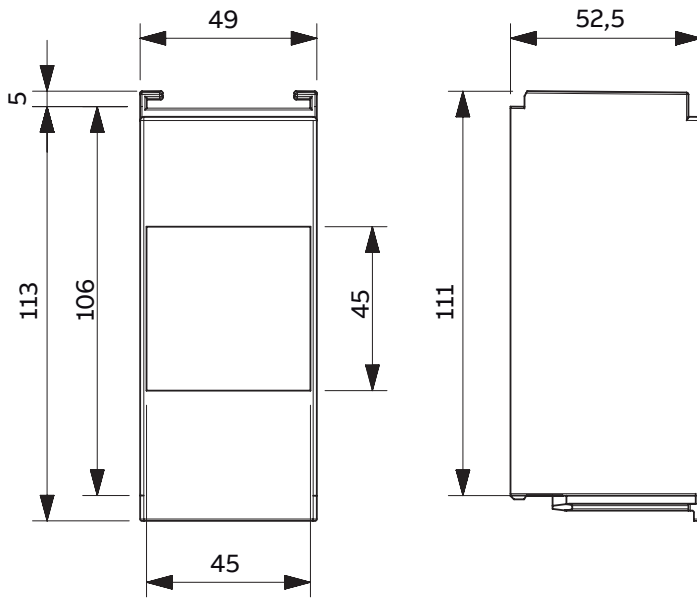

I  
ZLBM1/2/3

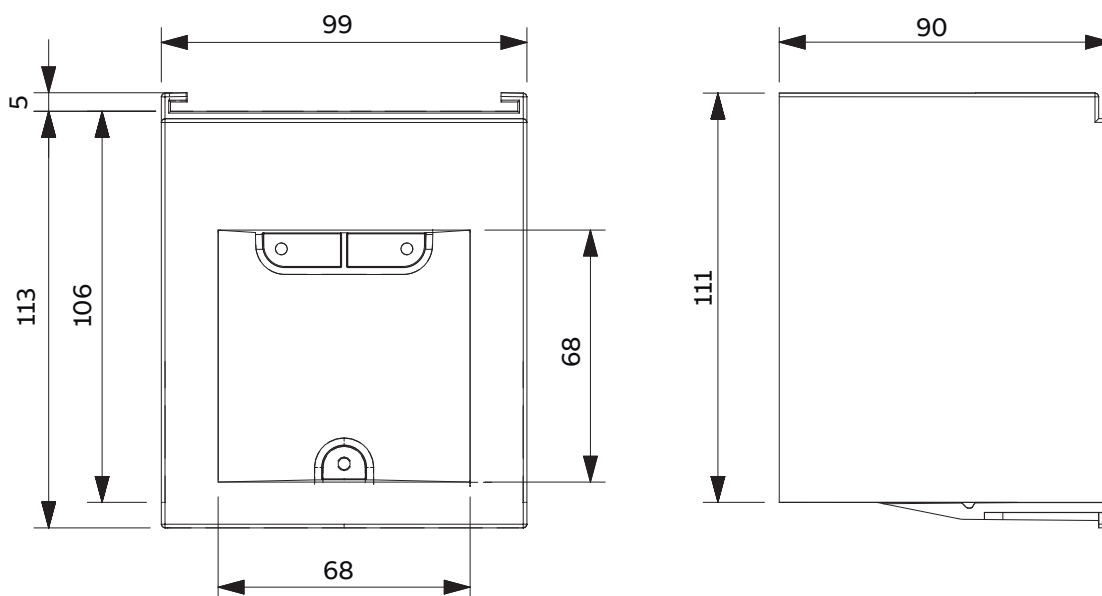

# Dimension drawings

## Label holders

### ZLBM00

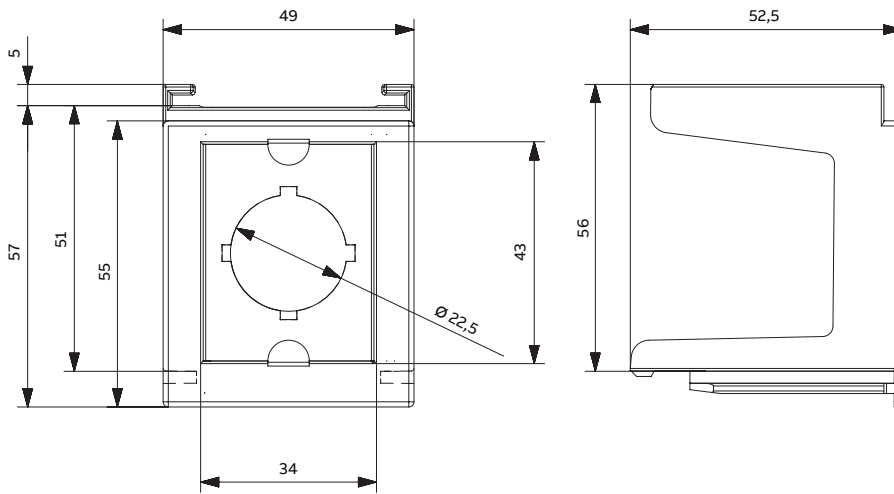

### ZLBM1/2/3

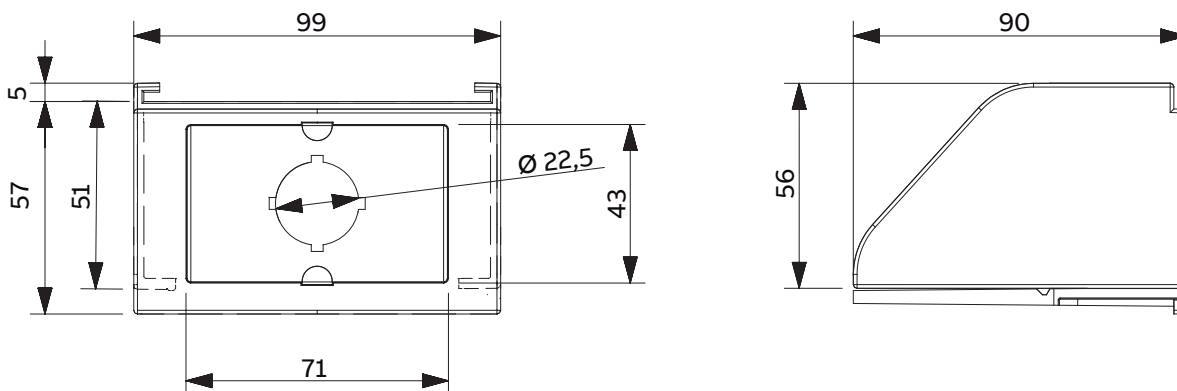

# Additional resources

## InLine II

InLine II website



800 V AC Fusegear



Video – InLine II features

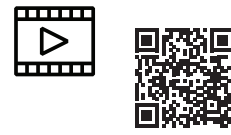

InLine II Cu+ for high ambient temperatures



Certificates

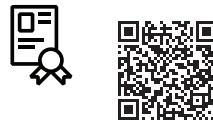

Drawings



E-configure



ITS2 Intelligent monitoring unit



Installation of ITS2.1 monitoring unit with InLine II

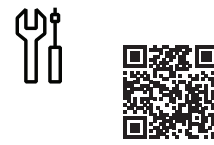



—  
**ABB Electrification,  
Smart Power**

**[www.abb.com](http://www.abb.com)**

Find the address of your local sales  
organization on the ABB homepage:

**[www.abb.com/contacts](http://www.abb.com/contacts).**